



TEKTELIC Communications Inc.
7657 10th Street NE Calgary, Alberta
Canada, T2E 8X2

CHICKADEE

Location Tracker

User Guide

Document Type: User Guide

Document Number: T0008814

Document Version: 1.4

Document Status: Released

**Product Names and
T-Codes:**

CHICKADEE

T0008534

Release Date: February 6, 2025

Document Revision History

Revision	Issue Date	Status	Editor	Comments
1.0	June 17, 2024	Obsolete	Mark Oevering	First draft
1.1	July 26, 2024	Obsolete	Mark Oevering	Updated Table 1-4
1.2	November 12, 2024	Obsolete	Mark Oevering	Added more T-codes to Table 1-1
1.3	January 7, 2025	Released	Mark Oevering	Clarified input power rating Added mounting information
1.4	February 6, 2025	Released	Mark Oevering	Updates to Section 1.3

Table of Contents

Document Revision History.....	2
Table of Contents.....	3
List of Tables	5
List of Figures	6
List of Acronyms.....	7
1 Product Description.....	8
1.1 Overview	8
1.2 Summary of HW Information, Streams, and Default Behaviour	10
1.3 External Appearance and Interfacing.....	11
1.4 Specifications and Sensing Functions.....	12
1.4.1 Tracking with Geolocation	14
1.4.1.1 Geolocation Strategies	16
1.4.1.2 GNSS and Wi-Fi Operation with LoRa Cloud Resolvers	18
1.4.1.3 BLE Operation with LOCUS and the GRB.....	19
1.4.2 MCU Temperature Sensing.....	19
1.4.3 Accelerometer Transducer	19
1.4.4 BLE Beacon Mode	20
2 Setup of the Sensor	22
2.1 Included Product and Installation Material	22
2.2 Unpacking and Inspection	22
2.3 Commissioning and Activation.....	22
2.4 Battery Replacement.....	23
2.5 Charging.....	23
2.6 Mounting.....	23
3 Operation, Alarms, and Management.....	25
3.1 Configuration.....	25
3.2 Default Configuration.....	25
3.3 LED Behaviour	25
3.3.1 Power-On and Network Join Patterns	26

3.3.2 Normal Operation Patterns 27

3.3.3 EMERGENCY Mode 27

4 Compliance Statements..... 28

Appendix 1 - List of Geolocation Strategies..... 30

References 33

List of Tables

Table 1-1: CHICKADEE HW Models	10
Table 1-2: List of CHICKADEE Information Streams	11
Table 1-3: CHICKADEE Default Reporting Behavior	11
Table 1-4: CHICKADEE Specifications.....	13
Table 1-5: Supported Geolocation Scan Technologies	15
Table 1-6: Scan Order Logic Options.....	16
Table 1-7: Geolocation Strategies.....	16
Table 3-1: Default Reporting Periods.....	25
Table 3-2: Summary of LED Patterns	25

List of Figures

Figure 1-1: CHICKADEE Location Tracking End-to-End Architecture 9

Figure 1-2: CHICKADEE Enclosure and External Interfacing 12

Figure 1-3: Periodic Geolocation Cycles and ULs..... 14

Figure 1-4: Default Geolocation Strategy Cycle Flow 18

Figure 1-5: The BLE Advertisement Scheme..... 21

Figure 2-1: Charging Contacts..... 23

Figure 2-2: Lanyard Clip Mounting Slot 23

Figure 2-3: Adhesive Tape Mounting Area 24

Figure 3-1: The GREEN POST Pass (left) and RED POST Failure (right) LED Patterns..... 26

Figure 3-2: The LED Patterns During JOIN Mode..... 27

Figure 3-3: EB activation and deactivation block diagram 27

List of Acronyms

BER	Bit Error Rate	LTC	Lithium-Thionyl Chloride
BLE	Bluetooth Low-Energy	MAC	Media Access Control
CNR	Cahiers des charges sur les Normes Radioélectriques (RSS)	MCU ..	MicroController Unit
DL	DownLink	NA	North America
EGNOS	Wuropean Geostationary Navigation Overlay Service	NLOS ..	Near LoS
EOS	End Of Service	NS	Network Server
EU	European Union	OTA	Over The Air
FCC	Federal Communications Commission	PCB	Printed Circuit Board
FSK	Frequency Shift Keying	PCBA ..	PCB Assembly
FW	FirmWare	Rev	Revision
GEO	GEOstationary Orbit	RF	Radio Frequency
GFSK	Gaussian FSK	RH	Relative Humidity
GNSS	Global Navigation Satellite System	RSS	Radio Standards Specifications (CNR)
GPS	Global Positioning System	RSSI	Received Signal Strength Indicator
GRB	Geolocation Resolver Backend	Rx	Receive, receiver, etc.
GW	GateWay	SBAS ..	Satellite Based Augmentation System
HW	HardWare	SW	SoftWare
ID	IDentifier	TLM ...	TeLeMetry
IGSO	Inclined GeoSynchronous Orbit	TRM ...	Technical Reference Manual
IoT	Internet of Things	Tx	Transmit, Transmitter, etc.
IP	Ingress Protection	UG	User Guide
ISM	Industrial, Scientific, and Medical	UID ...	Unique ID
LED	Light-Emitting Diode	UL	Uplink
LoRa	Long-Range	US	United States
LoRaWAN	LoRa Wide-Area Network	v	version
LoS	Line-of-Sight	WAAS	Wide Area Augmentation System
		Wi-Fi ..	Wireless-Fidelity

1 Product Description

1.1 Overview

This document provides a user manual for the *CHICKADEE Location Trackers* developed by TEKTELIC Communications Inc. This document includes instructions regarding the HW capabilities. For the functional operation and SW behaviour, please refer to the TRM document.

The CHICKADEE is a low-power LoRaWAN IoT sensor powered by a Li-Po rechargeable battery and built into a compact IP65 polycarbonate casing. Its primary purpose is for location tracking both indoors and outdoors using a combination of location-tracking technologies:

- **GNSS:** Outdoor tracking using satellite geolocation. There are two GNSS receivers built into Chickadee:
 - Low-power GNSS (LPGNSS) using the Semtech LR1110 transceiver.
Note: The acronym “LPGNSS” will refer to the LR1110 from this point on in this document.
 - High precision GNSS using the ublox MAX-M10S transceiver.
Note: The acronym “GNSS” will refer to the MAX-M10S from this point on in this document.
- **Wi-Fi Sniffing:** Outdoor and/or indoor tracking using Wi-Fi access point geolocation.
- **BLE Tracking:** Indoor tracking using BLE beacon network localization.

The CHICKADEE is meant to be a component in an end-to-end location tracking solution as shown in Figure 1-1.¹

LoRaWAN is the LoRa wireless communications standard protocol. This technology provides a low-bandwidth, low-power, and long-range² means of transmitting small amounts of data. It has been developed with wireless sensing in mind, and to enable new means of gathering telemetry in numerous environments. The CHICKADEE supports LoRa and (G)FSK modulations according to the LoRaWAN L2 1.0.4 Specification [1]. The 150 MHz-960 MHz ISM bands are utilized to meet

¹ **NOTE:** Only raw scan data is present in the LoRaWAN payloads, not sensor location information. In order to track and visualize a CHICKADEE’s location, an application server must be set up, integrated with the NS, and enabled to use the proper cloud location services. The information in this document is for the CHICKADEE sensor only; for information about setting up the rest of the end-to-end solution shown in Figure 1-1, refer to the TEKTELIC support portal Knowledge Base [1].

² Up to 2 km NLoS and more than 22 km LoS.

different application requirements from the standards and proprietary protocols of the given region.

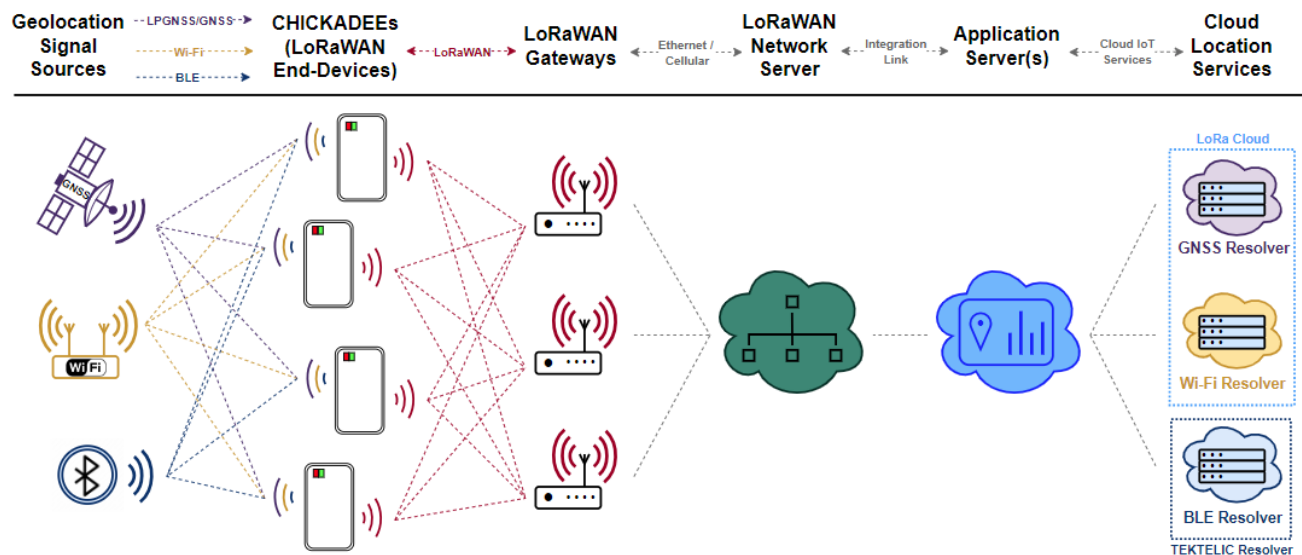

Figure 1-1: CHICKADEE Location Tracking End-to-End Architecture

The location information flows in this order:

1. CHICKADEE conducts LPGNSS, GNSS, Wi-Fi, and/or BLE scans to gather raw information from the available geolocation signal sources.
2. The raw scan results are conveyed via LoRa transmissions to 1 or more *LoRaWAN Gateways (GWs)*.
3. The GWs forward the packets to the *LoRaWAN Network Server (NS)* either by ethernet or cellular backhaul.
4. The raw scan results are forwarded to the application layer via *integration link*.
5. The application determines which *Cloud IoT Location Resolver Service(s)* to use depending on what type of scan data is forwarded. TEKTELIC's *LOCUS* application is designed to work natively with CHICKADEE, but any compatible 3rd-party application can be used.
6. The respective location resolver service processes the raw scan data to calculate a position fix.
 - a. LPGNSS scan data messages are designed to be processed by Semtech's *LoRa Cloud* service.
 - b. BLE scan data messages are designed to be processed by TEKTELIC's *Geolocation Resolver Backend (GRB)* and is supported by TEKTELIC's *LOCUS* application.
 - c. Wi-Fi scan data messages can be processed with 3rd party applications.
7. The resolved fixes are returned to the application where they can then be visualized on a virtual dashboard.

In addition to geolocation, CHICKADEE is a multipurpose device equipped with a variety of technology:

- **Core design:** Based on the low-power, IoT-targeted STM32WB55CGU6 MCU, which runs the system SW and has a built-in BLE module. The LR1110 transceiver from Semtech handles the LoRa, LPGNSS, and Wi-Fi operations. The MAX-M10S transceiver from u-blox handles the GNSS operations.
- **Accelerometer:** Detects device motion state so geolocation updates can be sent more frequently while in motion. Motion alarms and the raw acceleration vector can also be reported if knowledge of sensor orientation is enabled.
- **BLE tracker mode:** In this mode, the sensor is in BLE receive only to conduct geolocation tracking.
- **BLE beacon mode:** In this mode, the sensor broadcasts BLE advertisements which make it discoverable by other nearby trackers or BLE-capable devices.
- **MCU temperature sensing:** The temperature of the MCU can be reported, and additional reports can be sent if the conditions cross configurable thresholds.
- **Battery data:** The remaining capacity and lifetime can be reported. The battery lifetime has been estimated to be 6 months with default configuration.

1.2 Summary of HW Information, Streams, and Default Behaviour

Table 1-1 presents the currently available sensor HW variants. The information streams supported by the SW are shown in Table 1-2 and the default configuration for reporting data has been shown in Table 1-3.

Table 1-1: CHICKADEE HW Models

Product Code, Module Level T-code	Product Code, PCBA Level T-code	Model Name	Description	LoRaWAN regions supported
T0008534	T0008492	CHICKADEE	GNSS-Wi-Fi-BLE Location Tracking Sensor	EU868 US915
T0009142	T0008492	CHICKADEE	GNSS-Wi-Fi-BLE Location Tracking Sensor, Contact Charging	EU868 US915
T0009143	T0008492	CHICKADEE	GNSS-Wi-Fi-BLE Location Tracking Sensor – REGIONAL VARIANT 2	EU868 US915
T0009144	T0008492	CHICKADEE	GNSS-Wi-Fi-BLE Location Tracking Sensor, REGIONAL VARIANT 3	EU868 US915
T0009145	T0008492	CHICKADEE	GNSS-Wi-Fi-BLE Location Tracking Sensor – REGIONAL VARIANT 4	EU868 US915

Table 1-2: List of CHICKADEE Information Streams

Stream Direction	Data Type	Sent on LoRaWAN Port [decimal]
UL (Sensor to NS)	Reports containing sensor data: <ul style="list-style-type: none"> Battery life data Accelerometer vectors and alarms Ambient temperature Ambient RH Geolocation cycle failed message 	10
	Reports containing GNSS diagnostic information	16
	Reports containing discovered BLE device data	25
	Responses to read/write configuration and control commands	100/101
	GNSS scan results to be forwarded to LoRa Cloud	192
	Wi-Fi scan results to be forwarded to LoRa Cloud	197
	LoRa Cloud requests	199
DL (NS to Sensor)	Putting sensor into DEEP SLEEP	99
	Configuration and control commands	100
	LoRa Cloud communications	192/199

Table 1-3: CHICKADEE Default Reporting Behavior

Report	Report Type	Default Periodicity
Battery data	Periodic	24 hours
	Event-based	When function button is pressed
Geolocation Update	Periodic	10 min when in motion (LPGNSS) 1 hour when still (LPGNSS)
Acceleration vector	Periodic	Disabled
Accelerometer motion alarm	Event-based	When motion is detected When sensor becomes still
MCU temperature	Periodic	1 hour
	Threshold-based	Disabled

1.3 External Appearance and Interfacing

CHICKADEE enclosure is shown in Figure 1-2 and the locations of the external user interface hardware are identified. There are two buttons, the Function Button (FB) and the EMERGENCY button (EB). The Function button has three purposes and will act accordingly depending on how the button is pressed. These purposes are:

- a. **Activating the device:** When shipped from the factory, a CHICKADEE unit is in DEEP SLEEP mode to conserve the battery capacity. To wake it up and have it join the network, press the Function Button once quickly, then press and hold the button for 3 s. After this button pattern the unit will turn on and try to join the network server.
- b. **Forcing an uplink³:** Press the button and hold for 1 s to send an uplink which contains the battery status. The RED LED will flash indicating that the uplink was sent.
- c. **Resetting:** Press the button once quickly, then press and hold the button for 3 s.

The EMERGENCY button is for placing the sensor in EMERGENCY mode from normal mode, and for cancelling EMERGENCY mode. More details are in Section 3.3.3.

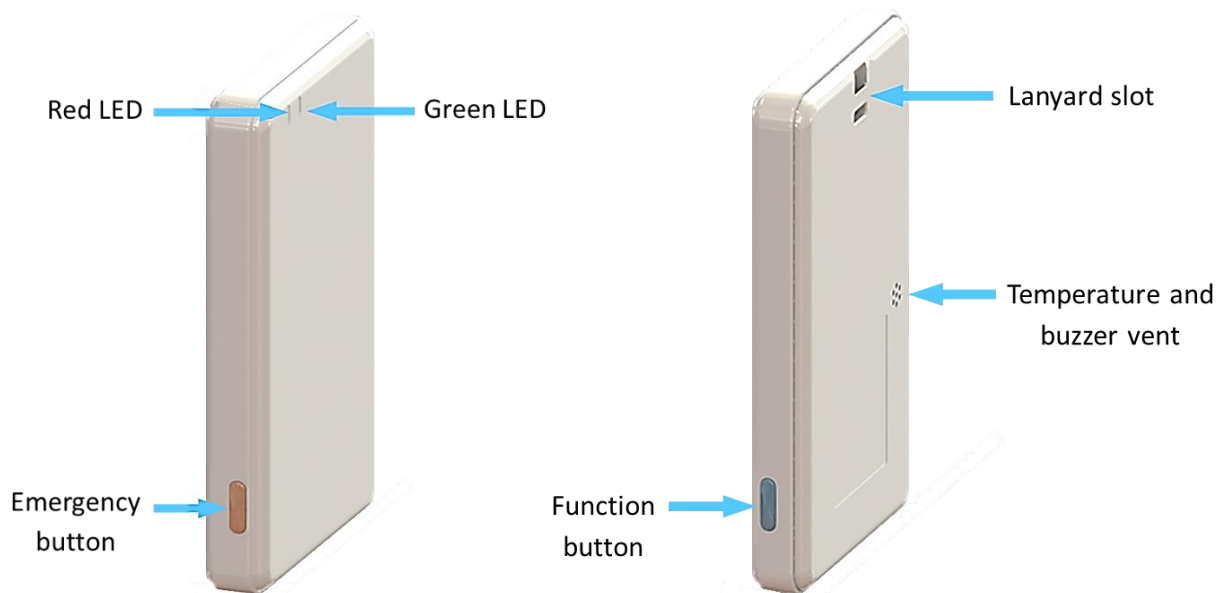

Figure 1-2: CHICKADEE Enclosure and External Interfacing

1.4 Specifications and Sensing Functions

The CHICKADEE specifications are listed in Table 1-4. The main sensing functions are described in the following subsections.

³ As a Class-A LoRaWAN end-device, the sensor only opens LoRaWAN receive windows immediately following uplink transmissions [3]. It is therefore useful to be able to force the sensor to UL so that it can receive DL configuration commands from the NS ahead of its next scheduled periodic report.

Table 1-4: CHICKADEE Specifications

Parameter	Specification
Use Environment	Indoor/outdoor commercial/residential
Environmental Rating	IP65
Enclosure and Mounting	Custom design by TEKTELIC, slot for lanyard loop
Operating Temperature	-10°C – 55°C
Charging Temperature	0 - 45°C
Storage Temperature for Optimal Battery Life (<3 months)	-10°C – 60°C
Storage Temperature for Optimal Battery Life (>3 months)	15°C – 30°C
Operating Relative Humidity	5% to 95% (non-condensing)
Storage Relative Humidity	10% to 100% (non-condensing)
Size	95 X 56 X 11 mm
Weight	84g
Battery	Internal non-replaceable rechargeable Lithium-Ion polymer
Power input	USB-C (5 V, 300 mA) or charging contacts (6 to 15 V d.c., 0.3 A maximum)
Network technology/Frequency band	LoRaWAN US915, EU868
Air Interfaces	LoRa, BLE, Wi-Fi, GNSS
Maximum Tx Power	<ul style="list-style-type: none"> • 14 dBm (LoRa) • 0 dBm (BLE)
Sensing Elements	LPGNSS receiver (LR1110), GNSS receiver (MAX10), Wi-Fi receiver, BLE transceiver, accelerometer, MCU Temperature, battery gauge
GNSS Constellations	<ul style="list-style-type: none"> • GPS L1 + GPS geostationary SBAS: EGNOS and WAAS • BeiDou B1 + BeiDou geostationary GEO/IGSO
Wi-Fi Compatibility	802.11b/g/n
Bluetooth Compatibility	BLE based on Bluetooth 5.3
LoRa RF Sensitivity	Up to -137 dBm (SF12, 125kHz BW)
BLE Sensitivity (PER <30.8%)	125 kbps: -103 dBm 500 kbps: -98 dBm 2 Mbps: -91 dBm
Accelerometer Sensitivity	Sample rate: 1 Hz, 10 Hz, 25 Hz, 50 Hz, 100 Hz, 200 Hz, 400 Hz Measurement range: ±2 g, ±4 g, ±8 g, ±16 g Accuracy: 16 mg, 32 mg, 64 mg, 192 mg
LEDs	Green: Joining the network activity Red: LoRa Tx or Rx activity Solid Red: Battery charging Solid Green: Battery charging complete
Battery Lifetime	6 months

1.4.1 Tracking with Geolocation

The primary purpose of the CHICKADEE is location tracking both indoors and outdoors using a combination of location-tracking technologies: **GNSS**, **LPGNSS**, **Wi-Fi sniffing**, and **BLE scanning**.

One or more geolocation scans are conducted during a *geolocation cycle*. A new geolocation cycle occurs at a regular period called the *geolocation update period*, as shown in Figure 1-3. By default, the geolocation update period is shorter when the sensor is in motion and longer when the sensor is still.

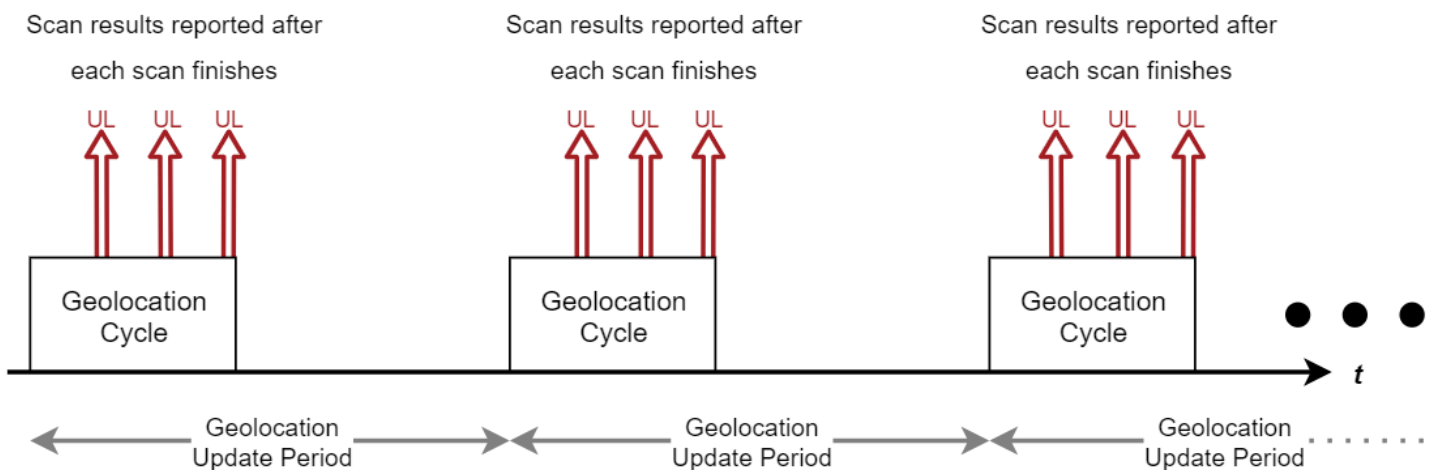

Figure 1-3: Periodic Geolocation Cycles and ULs

The satellite receiver can be configured to the user's preference; either LPGNSS or GNSS. LPGNSS is chosen by default for NORMAL operation mode. Should LPGNSS fail to get a positioning fix, the user can set whether or not to use GNSS as a backup.

During a geolocation cycle, up to 3 scans can be defined and occur in sequence. After each scan concludes, if successful, the raw results are reported in a LoRaWAN UL before the next scan begins⁴.

The duration of each geolocation cycle may vary from 10's of seconds to a few minutes, depending on several factors (e.g.: satellite signal strength, user configurable BLE scan duration, regional duty cycle limitations, etc.). It is important to configure the geolocation update period to be greater than the expected geolocation cycle duration, otherwise scans may not complete, and data may be lost. If LPGNSS scanning is enabled, it is not recommended to set the geolocation

⁴ If sending BLE scan results is paused due to regional duty cycle restrictions, the next scan (GNSS or Wi-Fi), if defined, will not begin until the duty cycle timeout expires and the BLE results are sent.

update period to less than 3.5 min. If BLE scanning is enabled, it is not recommended to set the geolocation update to less than 20 s.

The supported scan type options and behaviours are summarized in Table 1-5.

Table 1-5: Supported Geolocation Scan Technologies

Technology	Function	Results Format	Scan Failure Behaviour	Configurable Options
LPGNSS	LR1110 performs a low-power GNSS scan, then sends the scan results via LoRaWAN UL for LoRa Cloud to compute the position.	NAV message or message fragments containing satellite information.	Fail criteria ⁵ : too few satellites are detected, almanac is out of date, or clock is out of sync. No UL is sent unless all other scans in the cycle also fail.	<ul style="list-style-type: none"> • Clock sync parameters • Almanac update parameters • Assist coordinates • Satellite constellation (GPS/BeiDou/both) • Scan mode (mobile/static)
GNSS	MAX-M10S performs a GNSS scan, then sends the scan results via LoRaWAN UL.	Message fragments containing satellite information.	Send a blank UL on port 10.	<ul style="list-style-type: none"> • Report options • Diagnostic report options
Wi-Fi	LR1110 performs a Wi-Fi scan then sends the scan results via LoRaWAN UL for LoRa Cloud to compute the position.	Discovered Wi-Fi access point MAC addresses and RSSIs [dBm].	Fail criterion ⁵ : less than 3 Wi-Fi access points are discovered. No UL is sent unless all other scans in the cycle also fail.	None
BLE	MCU performs a BLE scan then sends the scan results via LoRaWAN UL for the GRB (Geolocation Resolver Backend) to compute the position.	Discovered BLE device MAC addresses and RSSIs [dBm].	Fail criterion: 0 BLE beacons detected. UL containing an empty list is sent.	<ul style="list-style-type: none"> • Scan duration • Scan duty cycle • Up to 4 discovered BLE device filters

⁵ The results of successful GNSS and Wi-Fi scan will fail to send if the sensor is restricted due to duty cycle at the time. Unlike other data reports, the scan results are dropped completely and not transmitted once the duty cycle timeout elapses. In these cases, if all other scans also fail, the *geolocation cycle failed* message will indicate this happened.

The *scan order logic* within the geolocation cycle is also configurable to allow the cycle to end upon a successful scan before the other defined scans occur. Doing so can save battery life in use-cases where the scan types can be prioritized by how likely they are to succeed, e.g.: if it is known that GNSS will be the available geolocation signal source 90% of the time. The supported scan order logic options are shown in Table 1-6.

Table 1-6: Scan Order Logic Options

A:	1 st scan	→	2 nd scan if 1 st scan fails	→	3 rd scan if 2 nd scan fails
B:	1 st scan	→	2 nd scan	→	3 rd scan if 2 nd scan fails
C:	1 st scan	→	2 nd scan if 1 st scan fails	→	3 rd scan
D:	1 st scan	→	2 nd scan	→	3 rd scan

1.4.1.1 Geolocation Strategies

The ability to define up to 3 scan types and choose 1 of 4 scan order logic options results in 12 possible configurational combinations. This combination is called the *geolocation strategy*. Of the 12 geolocation strategies, only 7 result in unique device behaviour, as shown by the green shaded boxes in Table 1-7.

Table 1-7: Geolocation Strategies

Strategy Description	Scan Order Logic	Number of Defined Scans		
		3	2	1
FALLBACK <ul style="list-style-type: none"> • 1st priority scan always done. • Fallback to other scan(s) upon failure. • End cycle upon successful scan. 	A	#1	#2	#7
1 BACKUP <ul style="list-style-type: none"> • 1st and 2nd priority scans always done. • 3rd scan if both 1st and 2nd scans failed. 	B	#3	#6	#7
2 BACKUPS <ul style="list-style-type: none"> • 1st priority scan always done. • 2nd and 3rd scans done if 1st scan failed. 	C	#4	#2	#7
ALL SCANS <ul style="list-style-type: none"> • All defined scans always done. 	D	#5	#6	#7

The geolocation strategy used should be tailored to the use case of the CHICKADEE deployment. Some example use-cases and strategies are:

- **Outdoor remote worker: FALLBACK with (1) LPGNSS or GNSS (2) Wi-Fi, (3) BLE**

Likely to be outside for most of the time, so LPGNSS or GNSS is likely to succeed most of the time. Wi-Fi is next most likely, then BLE.

- **Indoor worker: 2 BACKUP with (1) BLE, (2) Wi-Fi, (3) LPGNSS or GNSS**

Likely to be in an indoor BLE Beacon network most of the time, so BLE is likely to succeed most of the time. If BLE fails, try both other methods to get a position estimate.

The default geolocation strategy is fallback (scan order logic A) with all 3 scans defined in priority order GNSS, Wi-Fi, BLE. The operational flow of this strategy is depicted in Figure 1-4. All other strategy flow depictions are shown in Appendix 1 - List of Geolocation Strategies.

Geolocation Strategy 1 (Default) Fallback, All Scans Defined

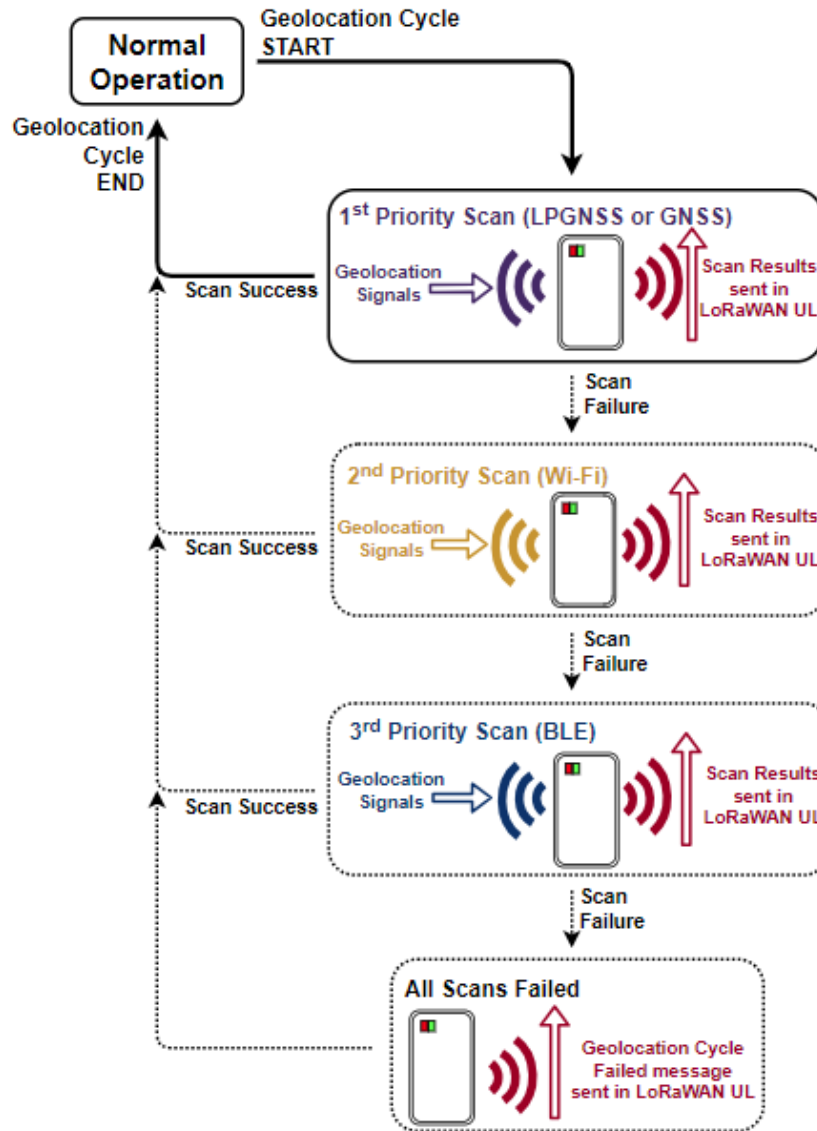

Figure 1-4: Default Geolocation Strategy Cycle Flow

With all geolocation strategies, if all scans fail, the *geolocation cycle failed* message is sent.

1.4.1.2 GNSS and Wi-Fi Operation with LoRa Cloud Resolvers

The GNSS and Wi-Fi scan results are formatted in such a way that the edge based LoRa Cloud service can resolve the sensor’s position. Both UL and DL communications are exchanged between the CHICKADEE and LoRa Cloud server to transfer all the information needed for the positions to be resolvable.

For LPGNSS scan results to be valid and resolvable, the following are needed:

- **Valid clock synchronization:** The internal time of the sensor must be synchronized periodically. The sync interval, sync expiration timeout, and sync service option are all configurable.
- **Valid almanac:** The almanac in the sensor must be kept up-to-date. The update check period and update request UL interval are configurable.
- **Assist coordinates:** These help the resolver with an initial estimate of the sensor's location. These can be configured specifically by the user if desired, but the SW will automatically communicate with LoRa cloud to obtain assist coordinates upon startup if none are defined.

Other user-configurable options for GNSS scanning include the choice of satellite constellation (GPS, BeiDou, or both) and mobile or static scanning. **Wi-Fi scanning has no configurable options.**

1.4.1.3 BLE Operation with LOCUS and the GRB

The BLE scan results are formatted in such a way that the TEKTELIC LOCUS application can resolve and display the sensor's position. Indoor BLE beacon networks can be built virtually in LOCUS to match the physical setup. When LOCUS receives a sensor UL with raw BLE scan data, it forwards it to the *Geolocation Resolver Backend* (GRB) cloud service, which computes and returns the position estimate within the beacon network.

For information about setting up LOCUS, refer to the TEKTELIC support portal *Knowledge Base* articles [2]. For a description of BLE scan behaviour, see the TRM.

1.4.2 MCU Temperature Sensing

CHICKADEE can send data for MCU temperature [°C], read from the MCU, in a LoRaWAN UL. Sampling cannot be disabled, but reporting can be disabled. By default, temperature is reported once every hour.

Threshold ranges can also be set such that moving in or out of range causes additional MCU temperature data reports.

1.4.3 Accelerometer Transducer

The CHICKADEE supports motion sensing through an integrated 3-axis accelerometer which can optionally be disabled. The main role of the accelerometer in the is to detect motion that can indicate a change of the sensor's status from stillness to mobility, or vice versa.

The accelerometer generates an acceleration alarm when a motion event is detected that can be reported OTA. An acceleration event report is based on exceeding a defined acceleration alarm threshold count in a defined alarm threshold period. These thresholds can be customized such that there will not be multiple reports for a single event, depending on the definition of an event in a particular use case. An alarm event can only be registered after a configurable grace period elapses since the last registered alarm event. Carefully setting the grace period is important and prevents from repeatedly registering an accelerometer event.

In addition to alarms, detected motion can trigger the transitions between geolocation update periods. That is, when the ***Accelerometer Assist*** function is enabled:

- When new motion is detected:
 - A new geolocation cycle begins immediately.
 - New geolocation cycles occur periodically according to the MOBILE geolocation update period.
- When the motion has ended:
 - A new geolocation cycle begins immediately.
 - New geolocation cycles occur periodically according to the STILL geolocation update period.

The geolocation update periods are both configurable.

For location tracking, Accelerometer Assisted geolocation scans help to get location updates at appropriate rates: faster when moving and slower when still. Accelerometer Assist also helps to update the location at 2 critical times; when objects leave old locations and settle in new ones. Accelerometer Assist is enabled by default.

The accelerometer can also be polled periodically for its output acceleration vector for applications in which the sensor's orientation is of interest.

1.4.4 BLE Beacon Mode

The CHICKADEE supports a *beacon mode* function as an alternative to geolocation tracker mode. The default mode of the sensor is tracker mode, so it must be switched into beacon mode.

When in beacon mode, no geolocation scans occur and the BLE operates in Tx only. It sends out periodic *advertisements* which are small packets of data. These packets are discoverable by other CHICKADEEs operating in tracker mode, as well as any other device capable of BLE scanning.

When in beacon mode, the sensor is still LoRaWAN-backhauled. That is, it can still send sensor data in LoRaWAN ULs and be reconfigured through LoRaWAN DLs. Furthermore, all other transducer functions are accessible in either beacon or tracker mode.

After a beacon joins the LoRaWAN network, it begins broadcasting BLE advertisements. This continues throughout normal operation as a background process.

The *advertising interval* is the time between the beginnings of consecutive advertisement transmissions as shown in Figure 1-5. It is user-configurable in units of [ms].

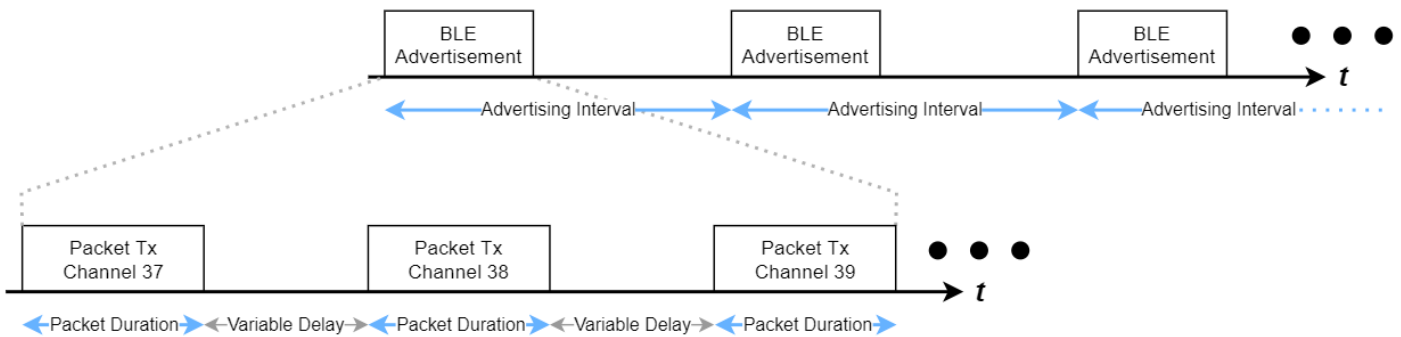

Figure 1-5: The BLE Advertisement Scheme

Figure 1-5 also shows that each single BLE advertisement comprises 3 individual packet transmissions, sent one after another on BLE channels 37, 38, and 39 [3]. This is to maximize the chances of a BLE device scanning on a single channel receiving 1 packet per advertising interval.

In addition to the advertising interval, the advertisement *Tx power* level is also a configurable operational parameter.

The BLE advertisement and LoRa radio transmission are mutually exclusive and never overlap. If any reporting becomes due, the BLE advertisements are paused while the LoRa activity is occurring.

The BLE advertising packet formatting supports 3 major BLE standards: iBeacon, Eddystone UID, and Eddystone TLM. By default, only iBeacon is enabled.

2 Setup of the Sensor

2.1 Included Product and Installation Material

The following items are shipped with each sensor:

- 1x sensor with 3.7 V Li-Ion battery installed. The battery is not replaceable by the user.
- 1x lanyard clip
- 1x Quick Start Guide

2.2 Unpacking and Inspection

The following should be considered during the unpacking of a new sensor.

Inspect the shipping carton and report any significant damage to TEKTELIC.

Unpacking should be conducted in a clean and dry location.

Do not discard the shipping box or inserts as they will be required if a unit is returned for repair or reprogramming.

2.3 Commissioning and Activation

Each sensor has a set of commissioning information that must be entered into the network server for the sensor to be able to join the network and begin normal operation once activated. For instructions on how to do this please refer to the Network Server Quick Start Guide (available online in the *Knowledge Base*) [5]. The commissioning info is included on the package labels.

The sensor is shipped in a secured enclosure with the battery preinstalled in a state of DEEP SLEEP. After unpackaging a CHICKADEE, the user must charge the battery when CHICKADEE is removed from the shipping box. This is done through the USB-C connector at the base of the unit by using a USB-C cable, or by the charge contacts (requires a custom adapter provided by TEKTELIC). The **RED** LED will be solid while the battery is charging and will turn to solid **GREEN** when charging is complete. Charging will take approximately 5 hours to complete.

Pressing the Function Button will activate CHICKADEE (see Section 1.3), and it will try to join the network server. When the CHICKADEE is activated, it will display an LED indication (described in §3.3) to show that it is beginning to join the network. It may take up to 10 seconds between the time of activation and the beginning of the LED join attempt pattern.

Once activated, the sensor will automatically begin the join process. CHICKADEE cannot be turned off by the user.

2.4 Battery Replacement

The battery is non-replaceable, return the unit to TEKTELIC for service.

2.5 Charging

The CHICKADEE can be charged from a standard USB-C connector or through the external charging contacts on the bottom end of the module. Simultaneous application of power to both inputs is not allowed. Charging through the charging contacts requires the use of a custom charger cradle supplied by TEKTELIC.

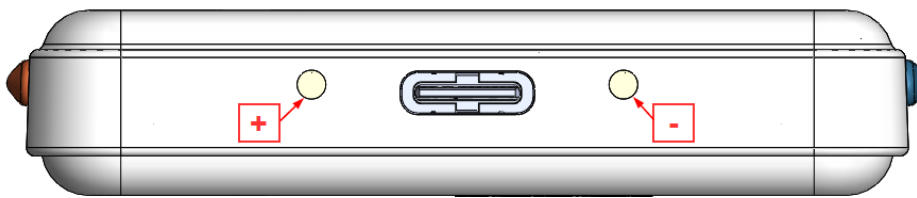

Figure 2-1: Charging Contacts

2.6 Mounting

The CHICKADEE is primarily intended to be body worn using the provided lanyard clip.



Figure 2-2: Lanyard Clip Mounting Slot

The CHICKADEE may also be mounted to a material object using adhesive tape provided the module is mounted no more than 2 m above floor level.



Figure 2-3: Adhesive Tape Mounting Area

3 Operation, Alarms, and Management

3.1 Configuration

The CHICKADEE supports a full range of OTA configuration options. Specific technical details are available in the corresponding TRM documents. All configuration commands need to be sent OTA during the sensor's DL Rx windows.

3.2 Default Configuration

Table 3-1 lists the default reporting behaviour of the CHICKADEE. Reporting behaviour can be changed from default through OTA DL commands.

Table 3-1: Default Reporting Periods

Reported Data	Reporting Period
Battery Data	24 hours
Geolocation Update Data	1 hour when STILL 10 minutes when MOBILE
MCU Temperature	1 hour
Acceleration Vector	Disabled

3.3 LED Behaviour

The LED behaviour is not user configurable.

The LEDs are normally off. Their blinking patterns reflect different actions and states of the sensor. At a high-level, the main patterns are summarized in Table 3-2. The detailed sequence and timings for each are described in the following subsections.

Table 3-2: Summary of LED Patterns

LED Pattern	Meaning
GREEN blinking rapidly and single RED flash every 10 s	JOIN mode; attempting to join the network
Single RED flash	UL sent
Single GREEN flash	DL received
3 quick RED flashes	Entering DEEP SLEEP

3.3.1 Power-On and Network Join Patterns

When the sensor is activated or reset:

1. Both **GREEN** and **RED** are OFF for approximately 0.5 s after any reset occurs.
2. Upon startup, the SW conducts its POST. Both **GREEN** and **RED** are turned on when the POST begins.
3. When the POST ends (about 2 s), both **GREEN** and **RED** are turned off. Immediately following, the sensor will do 1 of 2 things, depending on the POST result:
 - a. If the POST passes, **GREEN** is toggled ON and OFF 3 times: every 100 ms for 0.6 s, as shown in Figure 3-1. In this case, the LED pattern proceeds to step 4.3
 - b. If the POST fails, **RED** is toggled ON and OFF 3 times: every 100 ms for 0.6 s, as shown in Figure 3-1. In this case, the device restarts and the LED pattern begins again at step 1 after approximately 4 s.

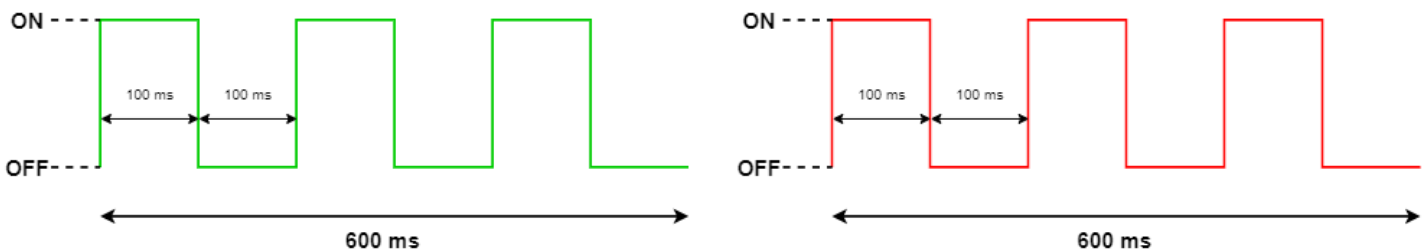

Figure 3-1: The GREEN POST Pass (left) and RED POST Failure (right) LED Patterns

4. After a successful POST, both **GREEN** and **RED** are turned off. Immediately following this, the sensor will enter JOIN mode and begin attempting to join the network. For the first hour:
 - a. **GREEN** is toggled ON and OFF every 50 ms for the first hour.
 - b. **RED** flashes just once:
 - i. with a pulse duration of 25 ms right after transmitting a JOIN REQUEST. This occurs at approximately 10 s intervals at the beginning of the join process, but at decreasing regularity the longer the join process continues due to battery saving measures and possible duty-cycle limitations in certain regions [7].
 - ii. with a pulse duration of 100 ms right after receiving a JOIN ACCEPT. This will occur once, after which, the device will have joined the network and normal operation begins.

If the sensor has been unsuccessfully trying to join for more than an hour, it enters *join back-off* to conserve power. While the sensor still attempts to join, **GREEN** stops flashing and **RED** flashes twice (ON time: 10 ms, OFF time: 10 ms) every 8 s. The JOIN LED pattern is shown in Figure 3-2.

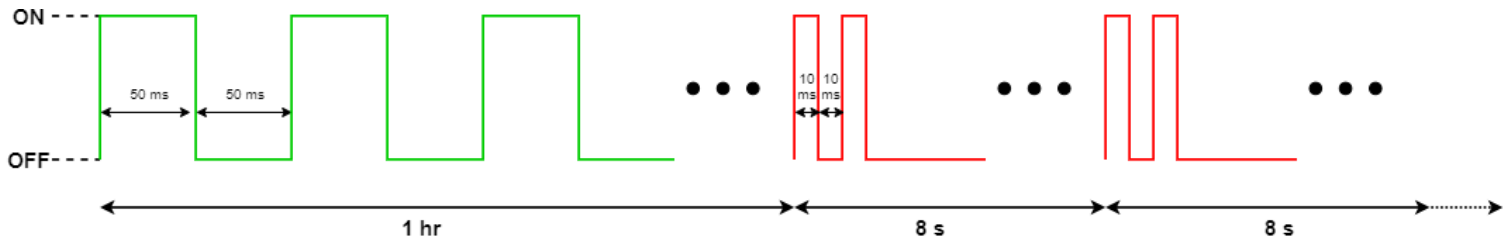

Figure 3-2: The LED Patterns During JOIN Mode

3.3.2 Normal Operation Patterns

After the Sensor has joined the network:

- RED** flashes just once with a pulse duration of 25 ms right after transmitting an uplink.
- GREEN** flashes just once with a pulse duration of 100 ms right after receiving a downlink.

3.3.3 EMERGENCY Mode

CHICKADEE is equipped with an Emergency Button (EB), which is used for the following purposes:

- EB Active event: Pressing and holding the EB for at least 2 s sounds the buzzer⁶ with the emergency active buzz pattern, flashes the LEDs, sends location information, and makes a system state transition to the EMERGENCY state (if already not in that state). The buzzer will repeat the pattern every 10 s while in the EMERGENCY state.
- EB Inactive event: Pressing and holding the EB for at least 2 s while in the EMERGENCY state turns the buzzer off, stops the periodic LED flashes, sends location information, and makes a system state transition to the NORMAL state.

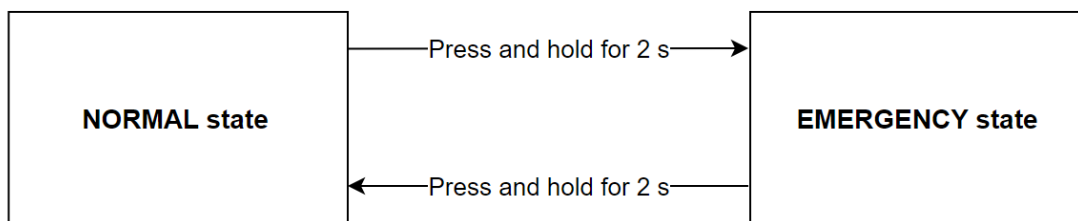

Figure 3-3: EB activation and deactivation block diagram

Note: While in the EMERGENCY state, GNSS will be used exclusively in the geolocation scans.

Geolocation cycles and scan order logic, as explained in §1.4.1.1, are configurable while CHICKADEE is in EMERGENCY STATE.

⁶ The buzz pattern for entering and exiting EMERGENCY state is non-configurable.

4 Compliance Statements

Federal Communications Commission:

This device complies with Part 15 of the FCC Rules [8]. Operation is subject to the following two conditions:

1. This device may not cause harmful interference, and
2. This device must accept any interference received, including interference that may cause undesired operation.

To comply with FCC exposure limits for general population / uncontrolled exposure, this device should be installed at a distance of 20 cm from all persons and must not be co-located or operating in conjunction with any other transmitter.

Changes or modifications not expressly approved by the party responsible for compliance could void the user's authority to operate the equipment. This equipment has been tested and found to comply with the limits for a Class B digital device, pursuant to Part 15 of the FCC Rules. These limits are designed to provide reasonable protection against harmful interference in an industrial installation. This equipment generates uses and can radiate radio frequency energy and, if not installed and used in accordance with the instructions, may cause harmful interference to radio communications. However, there is no guarantee that interference will not occur in a particular installation. If this equipment does cause harmful interference to radio or television reception, which can be determined by turning the equipment off and on, the user is encouraged to try to correct the interference by one of the following measures:

- Reorient or relocate the receiving antenna.
- Increase the separation between the equipment and receiver.
- Connect the equipment into an outlet on a circuit different from that to which the receiver is connected.
- Consult the dealer or an experienced radio/TV technician for help.

Innovation, Science and Economic Development Canada (Industry Canada):

This device contains licence-exempt transmitter(s)/receiver(s) that comply with Innovation, Science and Economic Development Canada's licence-exempt RSS(s) [9]. Operation is subject to the following two conditions:

- i. This device may not cause interference, and
- ii. This device must accept any interference, including interference that may cause undesired operation of the device.

This device should be installed and operated with minimum distance 0.2 m from human body.

L'émetteur/récepteur exempt de licence contenu dans le présent appareil est conforme aux CNR d'Innovation, Sciences et Développement économique Canada applicables aux appareils radio exempts de licence. L'exploitation est autorisée aux deux conditions suivantes:

(1) L'appareil ne doit pas produire de brouillage.

(2) L'appareil doit accepter tout brouillage radioélectrique subi, même si le brouillage est susceptible d'en compromettre le fonctionnement.

Cet appareil doit être installé et utilisé à une distance minimale de 0.2 m du corps humain.

California Proposition 65:

 **WARNING:** This product can expose you to chemicals including lead, nickel, and carbon black, which are known to the State of California to cause cancer, birth defects or other reproductive harm. For more information, go to www.P65Warnings.ca.gov [10].

Appendix 1 - List of Geolocation Strategies

Solid lines: process always done. Dotted lines: process done under certain conditions.

Geolocation Strategy 1 (Default)

Fallback, All Scans Defined

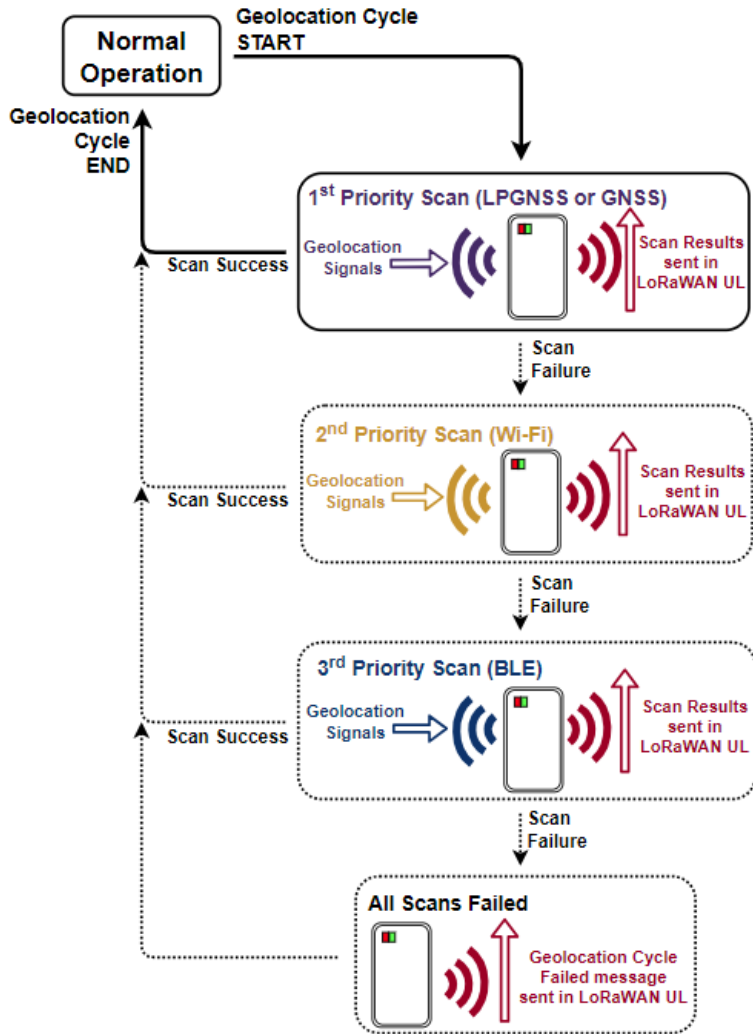

Geolocation Strategy 2

Fallback, 2 Scans Defined

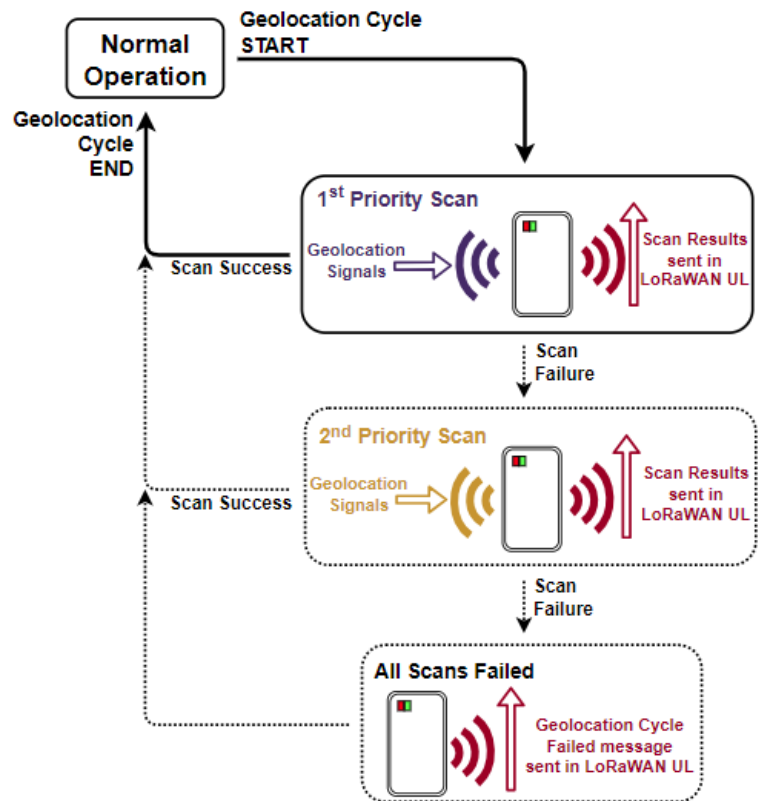

Geolocation Strategy 3 1 Backup, All Scans Defined

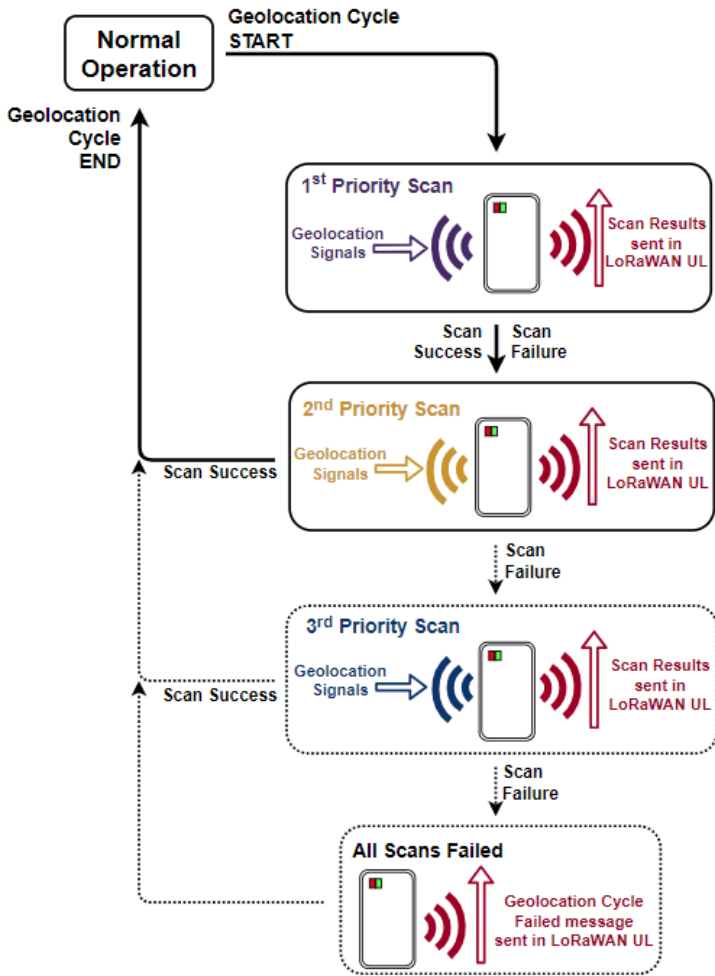

Geolocation Strategy 4 2 Backups, All Scans Defined

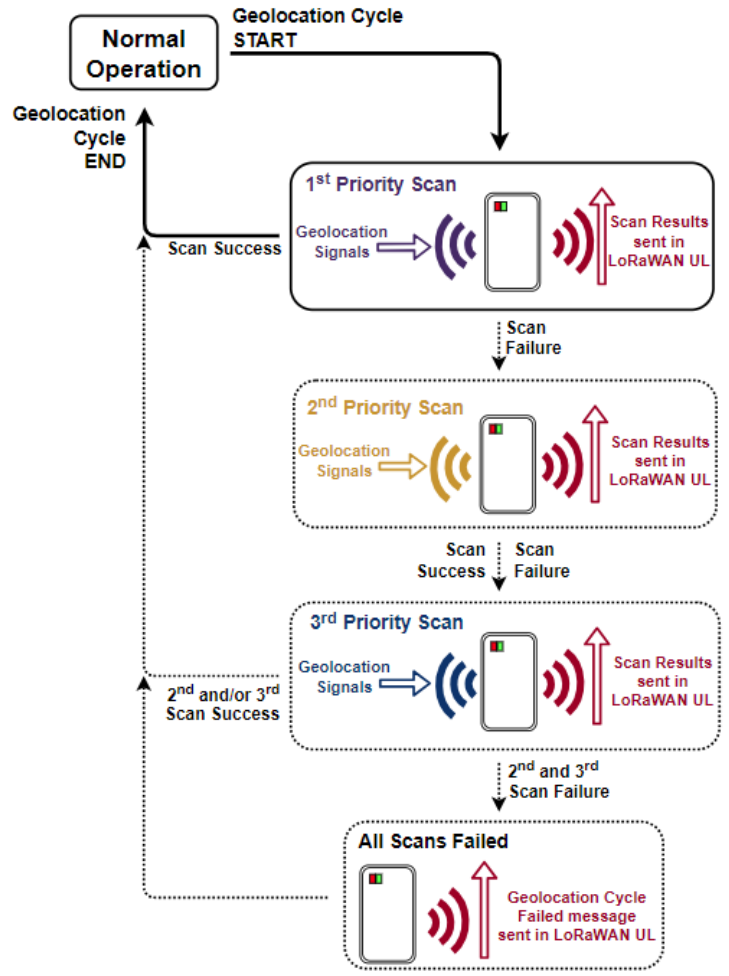

Geolocation Strategy 5
All Scans, All Scans Defined

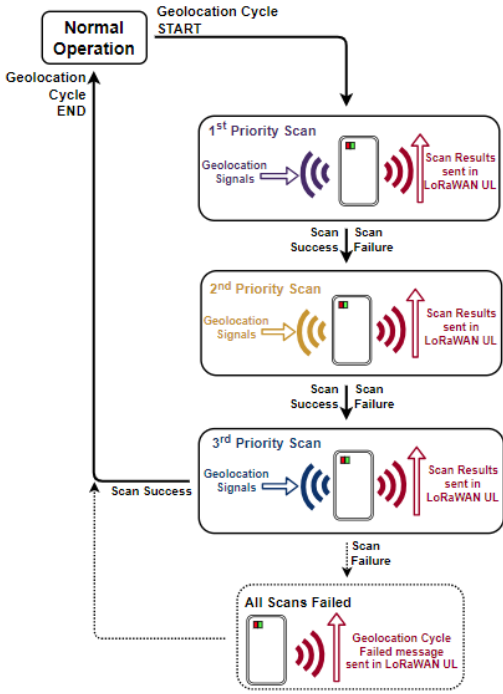

Geolocation Strategy 6
All Scans, 2 Scans Defined

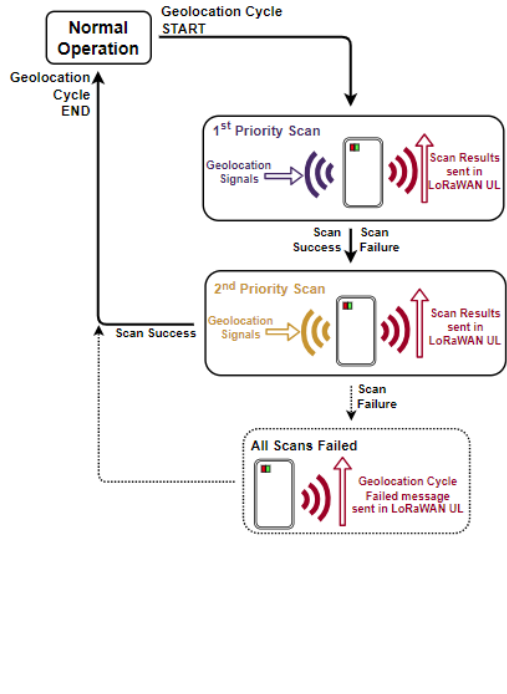

Geolocation Strategy 7
All Scans, 1 Scan Defined

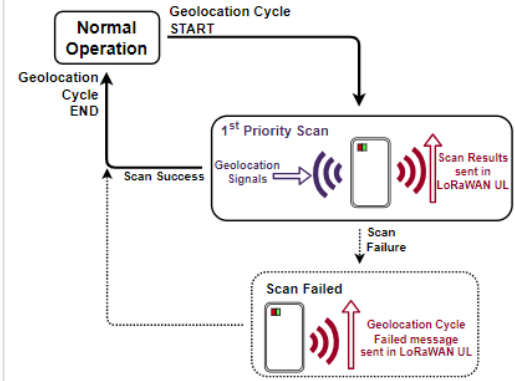

References

- [1] LoRa Alliance, Inc., "TS001-1.0.4 LoRaWAN® L2 1.0.4 Specification," October 2020. [Online]. Available: <https://resources.lora-alliance.org/technical-specifications/ts001-1-0-4-lorawan-l2-1-0-4-specification>. [Accessed 31 October 2023].
- [2] LoRa Alliance, "LoRaWAN™ 1.0.2 Regional Parameters," February 2017. [Online]. Available: https://lora-alliance.org/wp-content/uploads/2020/11/lorawan_regional_parameters_v1.0.2_final_1944_1.pdf. [Accessed 12 April 2021].
- [3] Bluetooth SIG, "Core Specification 5.0," 6 Dec 2016. [Online]. Available: <https://www.bluetooth.com/specifications/specs/core-specification-5/>. [Accessed 15 November 2021].
- [4] TEKTELIC Communications Inc, "Network Server Quickstart Guide - Creating Your first network," 21 August 2019. [Online]. Available: <https://support.tektelic.com/support/tektelic/ShowHomePage.do?articlestatus=published#Solutions/dv/274696000014617215/en/History>. [Accessed 12 April 2021].
- [5] Tensility International Corporation, "10-03011," Tensility, 14 09 2018. [Online]. Available: <https://tensility.com/cable-assemblies/10-03011>. [Accessed 14 05 2024].
- [6] LoRa Alliance, "LoRaWAN Regional Parameters," v1.0.2, rev. B, Feb 2017.
- [7] Office of the Federal Register, "Electronic Code of Federal Regulations: Title 47; Part 15 - Radio Frequency Devices," e-CFR, 28 February 2020. [Online]. Available: https://www.ecfr.gov/cgi-bin/text-idx?SID=86ed79fc9447ceff183191690a733ec7&mc=true&node=pt47.1.15&rgn=div5#se47.1.15_11. [Accessed 3 March 2020].
- [8] Innovation, Science and Economic Development Canada, "RSS-Gen: General Requirements for Compliance of Radio Apparatus; Issue 5; Amendment 1," March 2019. [Online]. Available: [ic.gc.ca/eic/site/smt-gst.nsf/vwapj/RSS-Gen1amend12019-04EN.pdf/\\$FILE/RSS-Gen1amend12019-04EN.pdf](https://ic.gc.ca/eic/site/smt-gst.nsf/vwapj/RSS-Gen1amend12019-04EN.pdf/$FILE/RSS-Gen1amend12019-04EN.pdf). [Accessed 3 March 2020].

- [9] OEHHA, "Proposition 65," California Office of Environmental Health Hazard Assessment, 2020. [Online]. Available: <https://oehha.ca.gov/proposition-65>. [Accessed 3 March 2020].
- [10] TEKTELIC Communications Inc., "BLE Asset Tracker: Technical Reference Manual T0005946_TRM_v0.4," TEKTELIC Communications Inc., Calgary, 2019.
- [11] TEKTELIC Communications, Inc., *BLE ASSET Tracker Quick Start Guide T0005946_QSG_ver1.0*, Calgary, 2020.
- [12] Bluetooth SIG, "Bluetooth Core Specifications v 5.0," 6 December 2016. [Online]. Available: <https://www.mouser.it/pdfdocs/bluetooth-Core-v50.pdf>. [Accessed 12 April 2021].
- [13] Semtech, "LoRa Cloud Modem and Geolocation Services," Semtech, 2023. [Online]. Available: https://www.loracloud.com/documentation/modem_services?url=index.html. [Accessed 9 11 2023].