

SEAL Wearable GPS Tracker



User Guide

Document Version:	v2
Product Name:	SEAL Wearable GPS Tracker
Issue Date:	May 30, 2024

PROPRIETARY:

The information contained in this document is the property of TEKTELIC Communications Inc. Except as specifically authorized in writing by TEKTELIC, the holder of this document shall keep all information contained herein confidential, and shall protect the same in whole or in part from disclosure to all third parties.

Table of Contents

- 1 Product Description 3
 - 1.1 Overview..... 3
 - 1.2 Specifications..... 5
- 2 Operating Instructions 7
 - 2.1 Included Product and Installation Material 7
 - 2.2 Safety Precautions..... 7
 - 2.3 Unpacking and Inspection 7
 - 2.4 Commissioning 7
 - 2.5 Activation..... 8
 - 2.6 Default Configuration 8
 - 2.7 Reconfiguration 8
 - 2.8 Mounting..... 9
 - 2.9 Battery Replacement..... 9
 - 2.10 LED Behaviour 10
 - 2.11 Activation, Putting to DEEP SLEEP, Resetting, and Shutting Down..... 10
- 3 Operation 11
 - 3.1 Features Details..... 11
 - 3.2 Push Buttons 11
- 4 Basic Downlinks 12
- 5 Device Configuration with ATLAS 14
- 6 Data converters 16
- 7 Compliance Statements..... 17
- Acronyms and Glossary..... 19

1 Product Description

1.1 Overview

SEAL is a light, small factor, long battery lifetime, low-cost LoRaWAN sensor used as a wearable device for tracking people based on GNSS and BLE technologies.

SEAL is also available in ATEX/IECEx certified versions (SEAL Ex) for use in explosive atmospheres. Please refer to the SEAL Ex User Guide T0008740 for information specific to the SEAL Ex versions.

The SEAL device technical features:

- Semtech modem for LoRaWAN communication
- Low-power MCU tailored for IoT applications, with built-in BLE module
- High-sensitivity GNSS receiver
- Low-power 3-axis MEMS accelerometer
- Digital barometric air pressure sensor
- Push button for emergency/SOS/panic functions
- Buzzer to indicate emergency button press or harness disconnection
- Mute button to manually mute or unmute the buzzer
- Two sets of LEDs (one at the top, one at the front) for indicating emergency status, low battery, and system sleep mode.

SEAL comes in two versions, with and without a harness clip. The harness clip detects if the unit is clipped in place or not and triggers a local alarm.

Table 1-1: SEAL Wearable GPS Tracker Model

Model	Description	RF Region	Tx Band (MHz)	Rx Band (MHz)
T0008768	SEAL Wearable GPS Tracker	US915	923-928	902-915
T0008769	SEAL Wearable GPS Tracker with Harness Clip	EU868	863-870	863-870

The supported features of the different SEAL variants are tabulated below.

Table 1-2: Functional features of SEAL variants

Feature	SEAL Functional Variants	
	SEAL with harness clip	SEAL without harness clip
Battery Lifetime info (Percentage and days remaining)	✓	✓
GNSS Fix Position and time stamp	✓	✓
GNSS Danger zone (GEOFENCE)	✓	✓
GNSS data logging	✓	✓
Groundspeed	✓	✓
Discovered BLE devices	✓	✓

BLE Danger zone	✓	✓
Emergency button	✓	✓
Fall detection	✓	✓
Safety Harness detection	✓	X
Elevation detection	✓	✓
Atmospheric Pressure	✓	✓
Acceleration Vector Report	✓	✓
Temperature	✓	✓
GNSS Diagnostics info	✓	✓

Figure 1-1, Figure 1-2, and Figure 1-2 below illustrate the clip and the non-clip variants of SEAL.



Figure 1-1: The SEAL Wearable GPS Tracker – Clip Variant.



Figure 1-2: The SEAL Wearable GPS Tracker – Non-Clip Variant.

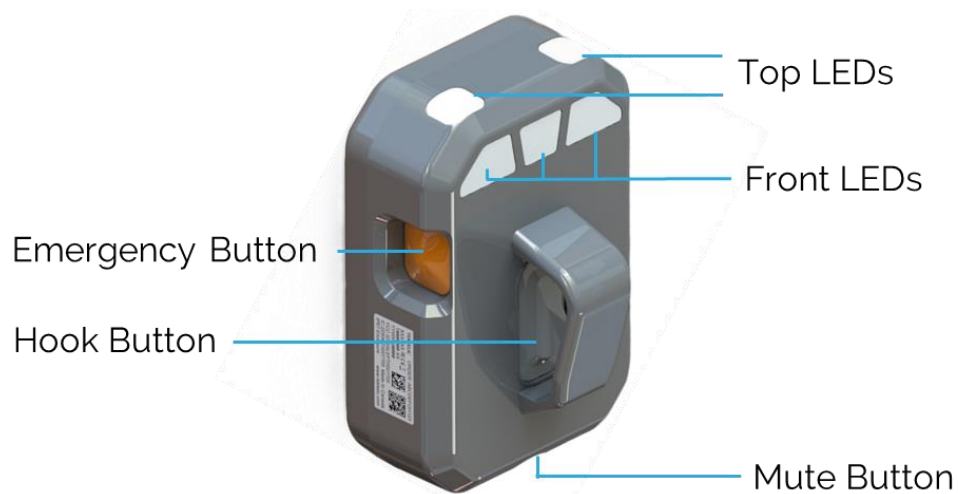

Figure 1-3: SEAL – LEDs and buttons (Harness clip version)

1.2 Specifications

The specifications for SEAL are listed in Table 1-3.

Table 1-3: SEAL Wearable GPS Tracker Specifications

Parameter	Specification
Use Environment	Indoor and outdoor locations
Form Factor	Wearable
Environmental Rating	IP67
Humidity Control	EPTFE vent
Operating Temperature	-20°C to 60°C
Storage Temperature for Optimal Battery Life	-25°C to 55°C
Size	Clip variant : 104 mm x 70 mm x 57.8 mm non-clip variant: 104 mm x 70 mm x 33.8 mm
Weight	100 g without batteries; add 15 g per battery.
Power Source	Battery powered: 3x AA-cell (1.5V) LID (replaceable)
Network technology/Frequency band	LoRaWAN EU868/US915/AS923/AU915/IN865/KR920/RU864
Air Interface	LoRa
Maximum Tx Power	15 dBm
Sensing Functions	GNSS, Accelerometer, BLE, Temperature, Pressure, Battery Gauge
GNSS Features	Support of GPS/QZSS, GLONASS, Galileo, BeiDou Support of up to 4 concurrent GNSSs Data logging up to 3,000 entries Geofencing up to 4 circular geofences 2.5 m position accuracy (CEP 50%) TTFF: <ul style="list-style-type: none"> • 60 sec cold start • 5 sec hot start Sensitivity:

	<ul style="list-style-type: none"> -160 dBm tracking and navigation -148 dBm cold start -157 dBm hot start
Accelerometer Sensitivity	Sample rate: 1 Hz, 10 Hz, 25 Hz, 50 Hz, 100 Hz, 200 Hz, 400 Hz Measurement range: $\pm 2 g$, $\pm 4 g$, $\pm 8 g$, $\pm 16 g$ Precision: 16 mg, 32 mg, 64 mg, 192 mg
Bluetooth Compatibility	BLE base on Bluetooth 5
BLE horizontal accuracy	$\leq 5 m$
BLE Sensitivity (0.1% BER)	125 kbps: -103 dBm 500 kbps: -98 dBm 2 Mbps: -91 dBm
BLE Danger Zones	Supports geofencing of up to 4 BLE mac address ranges
Temperature Measurement Accuracy	Accuracy: $< \pm 0.5 ^\circ C$
Barometric Pressure	Range: 300 to 1200 hPa Precision: $< \pm 0.002 hPa$ (or $\pm 0.02m$) Relative accuracy: $< \pm 0.06 hPa$ (or $\pm 0.5m$) Absolute accuracy: $< \pm 1 hPa$ ($\pm 8m$)
Battery Lifetime	16 months

Table 1-4: SEAL Battery Life Estimation

Reporting Frequency	SEAL Estimated Battery Life (days)
1 Tx / 24 Hours	5475
1 Tx / 1 Hour	1389
1 Tx / 15 Minutes (default)	415
1 Tx / 5 Minutes	145
1 Tx / 1 Minute	31

These estimates are made with the following assumptions:

- Default configurations are used for the lifetime of the sensor
- Active time of 10 hours, sleep time of 14 hours per day
- No emergency state is entered for the duration of the battery life
- The sensor is used outdoors in the open sky where the GPS signal is easily available

2 Operating Instructions

2.1 Included Product and Installation Material

The following items are included with each package:

- One SEAL Wearable GPS Tracker module with Lithium Iron Disulfide AA batteries installed
- A Quick Start Guide

2.2 Safety Precautions

The following safety precautions should be observed:

- Use only Energizer L91 Ultimate AA 1.5v Lithium Iron Disulfide batteries.
- Always replace all batteries together as a set with fresh new batteries.

2.3 Unpacking and Inspection

The following should be considered during the unpacking of a new SEAL product:

- Inspect the shipping carton and report any significant damage to TEKTELIC.
- Unpacking should be conducted in a clean and dry location.
- Don't discard the box or inserts as they will be required if a unit is returned for repair or re-configuration.

2.4 Commissioning

Each sensor has a set of commissioning information that must be entered into the network server before activation. For instructions on how to do this please refer to the Network Server Quick Start Guide you get in the box with the device (also available online in the [Knowledge Base](#)).

You can find the commissioning keys inside the box. If you don't have the box, please raise a ticket in our support portal and provide the Tcode and serial number on the tag placed on the device.



Figure 2-1 Commissioning Keys

2.5 Activation

SEAL is shipped in a closed enclosure with the batteries installed and engaged. However, SEAL is in a state of DEEP SLEEP.

To activate the unit:

1. Press the mute button for 1s, then release the mute button.
2. Press the mute button for 3-10 sec, then release the mute button.
3. The module will wake from a DEEP-SLEEP state and start joining the network.

NOTE: this button press pattern always triggers a module reset, even during normal operation.



Figure 2-2: SEAL with a clip showing the mute button.

2.6 Default Configuration

Table 2-1 lists the default reporting behavior of SEAL. Reporting behavior can be changed from default through OTA DownLink commands (see how to do it in [Basic Downlinks](#) section).

Table 2-1: Default Reporting Periods

Reported Data	Seal
Battery Status	24 hours
GNSS position fix and UTC timestamp GNSS Groundspeed	15 min in the NORMAL state 1 min in the EMERGENCY state
Safety Status (EB, Fall, SH, EAR, and Elevation alarm status)	5 min in the NORMAL state 1 min in the EMERGENCY state With any status change in EB, Fall, SH, EAR, or Elevation alarm

2.7 Reconfiguration

SEAL variants support a full range of OTA configuration options once the sensor has joined the network. Specific technical details are available in the corresponding TRM documents. All configuration commands need to be sent OTA during the sensor's DownLink Rx windows.

2.8 Mounting

On the battery side of the enclosure, there are four clip holes that can be used to clip the SEAL Tracker to a belt or harness clip as shown in Figure 2-3 below. The recommended clipping screw type is M3 5mm stainless steel screws. Separate mounting screws are not provided with the SEAL.

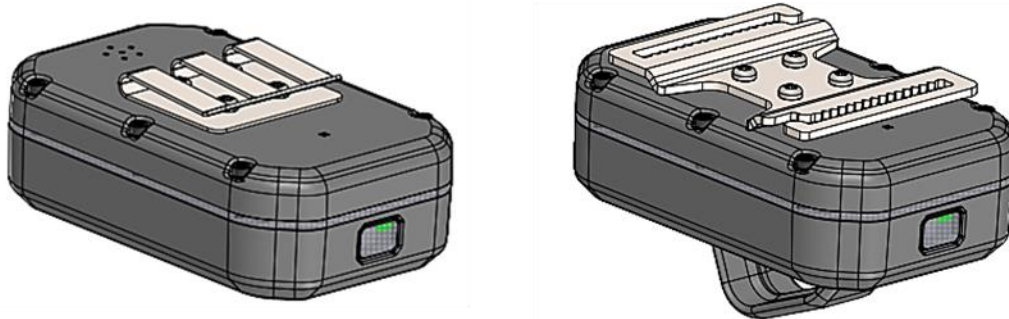

Figure 2-3: The Tracker clipped to a belt clip (Left) and harness clip (Right).

2.9 Battery Replacement

The SEAL module requires three Energizer L91 AA size Lithium Iron Disulfide “Ultimate Lithium” batteries. Always replace all batteries together as a set, observing polarity markings.

To replace the batteries in the SEAL module:

1. Use a 1.5 mm internal hex screwdriver to remove the battery cover secured by six hex socket head screws as in Figure 2-4.

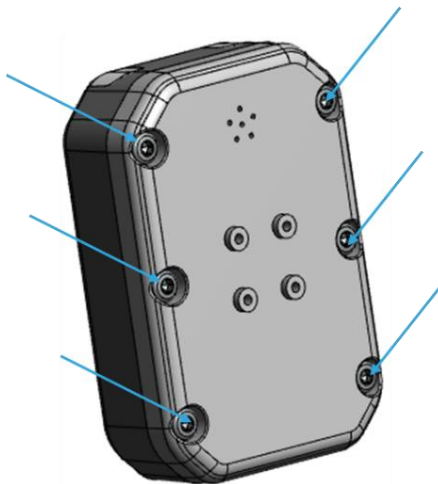
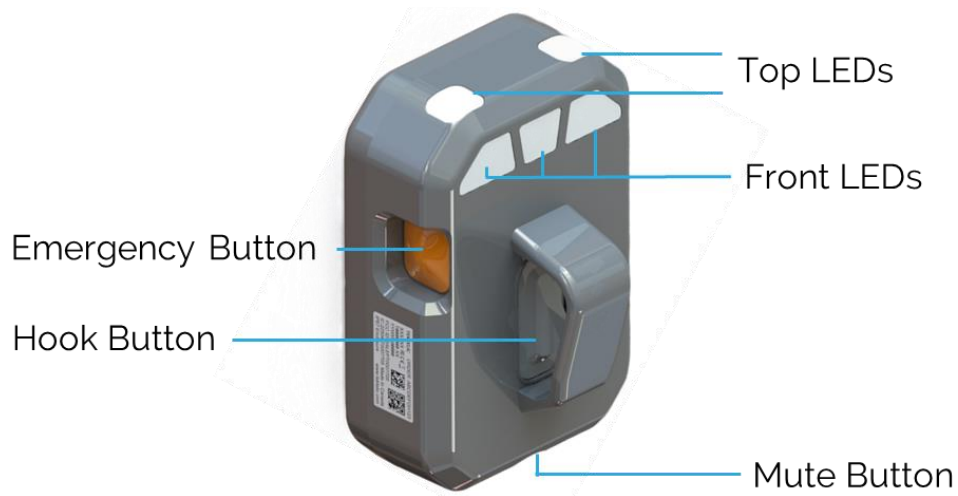

Figure 2-4: SEAL Hex Screws

2. Insert batteries and ensure the silicone gasket on the battery cover aligns properly for sealing.
3. Secure the battery cover with screws, tightening each to 2.5 lbs-in (30 N-cm).
4. SEAL will power on automatically and attempt to join the network.

2.10 LED Behaviour



See

Figure 1-3 for the location and identification of the SEAL LEDs.

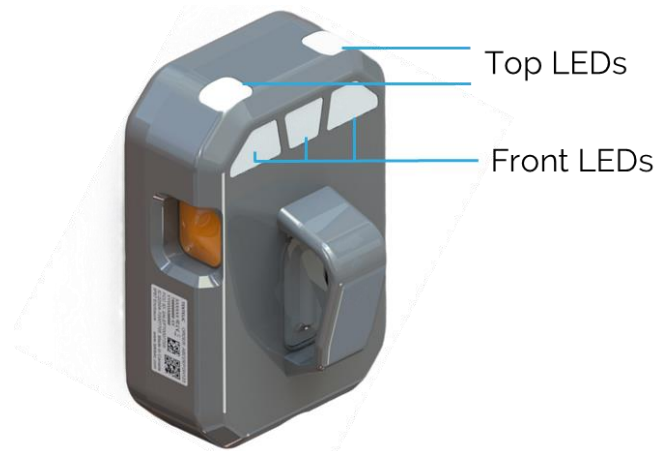

Figure 2-5: SEAL LEDs.

LED behavior during the boot and join process is described in Table 2-2.

Table 2-2: LED Behavior

LED Pattern	Meaning
All front LEDs are on	Device health self-check
Front LED flashes rapidly	Self-checks have failed (Consider replacing the batteries, or moving the SEAL Tracker to an environment within the temperature range)
Top LED flashes rapidly	Self-checks have passed and the device trying to join the network (join request every 10s). If not joined to the network after 1 hour, will switch to blinking every 10s.
Front LED blinks	Every LoRa uplink

2.11 Activation, Putting to DEEP SLEEP, Resetting, and Shutting Down

Error! Reference source not found. shows how to activate, put to DEEP SLEEP, reset, or completely turn off the SEAL Tracker.

Table 2-3: How to Activate, Put to DEEP SLEEP, Reset, or Shut Down SEAL

Desired Action	What to Do
Activate out of DEEP SLEEP	<ol style="list-style-type: none">1. Press the mute button for 1s, then release the mute button.2. Press the mute button for 3-10 sec, then release the mute button.
Put to DEEP SLEEP	Apply activation steps while the SEAL Tracker is trying to join the network
Reset	Apply activation steps to the SEAL Tracker in operation OR: Remove and reinsert the batteries
Completely power off	Remove the batteries

NOTE: Save your desired configuration to the flash before powering off, putting to DEEP SLEEP or resetting the SEAL or they will be lost.

3 Operation

3.1 Features Details

SEAL is equipped with a number of different features that are described in the table below.

Table 3-2: SEAL Features

Feature	Description
GNSS	Serves functions like localization, danger zone monitoring and data logging. It supports GPS, GLONASS, Galileo, and BeiDou, enhancing position availability even in dense urban areas. Accuracies of the GNSS position fixes are: a. Position accuracy (50% CEP): 2.5m b. Time to first fix: Cold start: 1-minute, Hot start: 5s
BLE	IoT module with BLE 5.2 support, used exclusively for tracking. It detects nearby BLE devices and can be activated via OTA command. It tracks and reports up to 128 devices per scan, remaining undetectable to other BLE trackers.
Accelerometer	Used for motion detection to awaken the device from sleep and for free-fall detection. It operates with ultra-low power and high performance, offering user-selectable full scales from $\pm 2g$ to $\pm 16g$. It can measure accelerations with output data rates from 1 Hz to 5.3 kHz.
Barometer	Accuracy measuring barometric pressure and temperature: 1. Operation range: Pressure: 300 –1200 hPa, temperature: -40 to 85 °C 2. Pressure sensor precision: ± 0.002 hPa (or ± 0.02 m) (high precision mode). 3. Relative accuracy: ± 0.06 hPa (or ± 0.5 m) 4. Absolute accuracy: ± 1 hPa (or ± 8 m) 5. Temperature accuracy: $\pm 0.5^\circ\text{C}$
Battery	Continuously monitors and computes remaining battery life

3.2 Push Buttons

SEAL has up to three push buttons described in Table 3.1

Table 3-1: SEAL Push Buttons

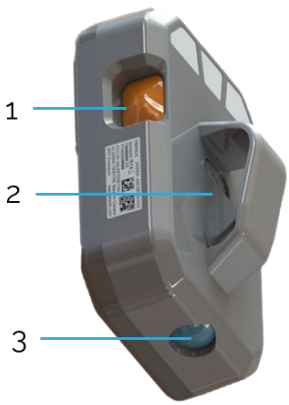
	Button		Purpose
	1	Emergency/panic button on the side	Activating and deactivating the emergency mode
2	Button at the front (only harness clip variants)	Detecting a harness connection	
3	Mute button on the base	Muting and unmuting the buzzer Resetting Putting the Tracker into and out of deep sleep	

4 Basic Downlinks

SEAL uses a "tick" system for reporting data. Generally, the sensor will report the most important data every tick. A tick can be measured in seconds.

There are two sets of settings that must be configured in conjunction - "Core reporting tick in seconds" and "Ticks per [data/report]".

"Core reporting tick in seconds" will determine the interval between ticks. For example, you may set it to 60 seconds or 180 seconds (3 minutes) for each tick.

"Ticks per [data/report]" determines how many ticks it will take before the sensor reports any data. For example, if you set "Ticks per Battery report" to 2, it will take 2 ticks before the sensor reports battery data.

To Change Core Report To Every Minute

With ATLAS: check the box for Core report tick in seconds and ticks between battery reports. Write the values shown in the Figure 4-1 and click send. The device will send the battery report every 60 seconds.

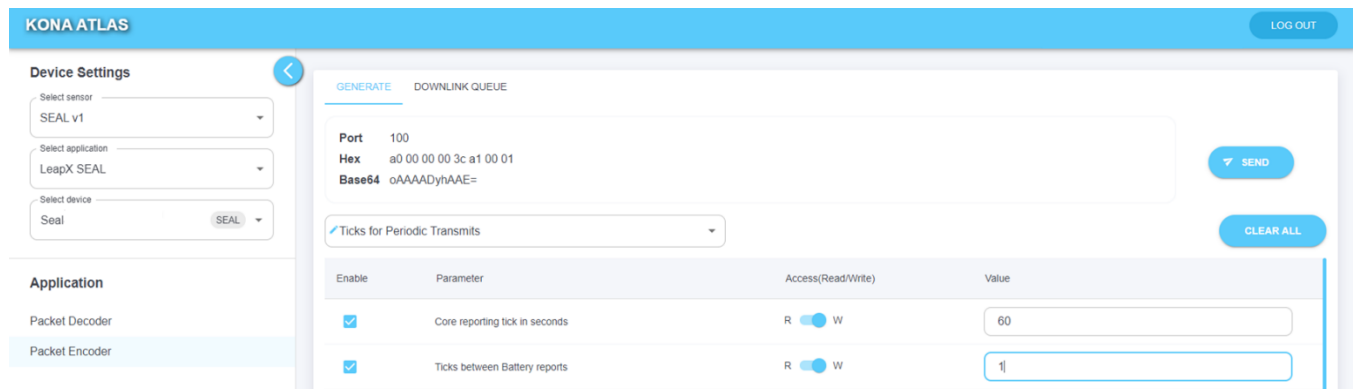

The screenshot shows the ATLAS web interface. On the left, there are dropdown menus for "Select sensor" (SEAL v1), "Select application" (LeapX SEAL), and "Select device" (Seal). Below these is an "Application" section with "Packet Decoder" and "Packet Encoder" options. The main area has tabs for "GENERATE" and "DOWNLINK QUEUE". It displays fields for "Port" (100), "Hex" (a0 00 00 00 3c a1 00 01), and "Base64" (oAAADyhAAE=). There are "SEND" and "CLEAR ALL" buttons. A table titled "Ticks for Periodic Transmits" is shown below, with columns for "Enable", "Parameter", "Access(Read/Write)", and "Value".

Enable	Parameter	Access(Read/Write)	Value
<input checked="" type="checkbox"/>	Core reporting tick in seconds	R <input checked="" type="checkbox"/> W	60
<input checked="" type="checkbox"/>	Ticks between Battery reports	R <input checked="" type="checkbox"/> W	1

Figure 4-1 ATLAS

Examples Of Uplinks

Example 1

```
"raw": "03 01 0D C3 5A 85 48 C4 C7 AE DE 6B 2B E5",  
"fport": 15,  
"fragment_number_3": 1,  
"year_3": 3,  
"month_3": 7,  
"day_3": 1,  
"hour_3": 21,  
"minute_3": 42,  
"second_3": 5,  
"latitude_3": "51.1654651",
```

```
"longitude_3": "-114.0907216",  
"altitude_3": "1129"
```

Example 2

```
"data": {  
  "raw": "0A AC 23 3F 8F 96 B1 AA AC 23 3F 8F 96 B2 AB",  
  "fPort": 25,  
  "basic_report": [  
    {  
      "BD_ADDR_0": "ac 23 3f 8f 96 b1",  
      "RSSI_0": -86  
    },  
    {  
      "BD_ADDR_0": "ac 23 3f 8f 96 b2",  
      "RSSI_0": -85  
    }  
  ]  
}
```

LeapX view

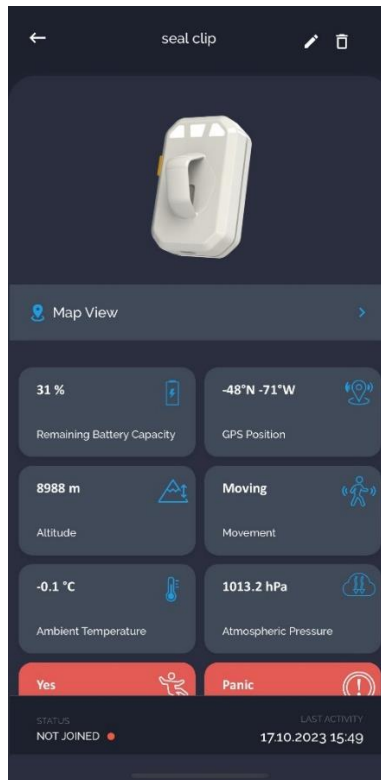

Figure 4-2 LeapX application

5 Device Configuration with ATLAS

To perform more configuration or read the data of SEAL device you can use TEKTELIC's complementary service, [ATLAS](#).

There are two ways to access ATLAS:

1) Using in Offline mode

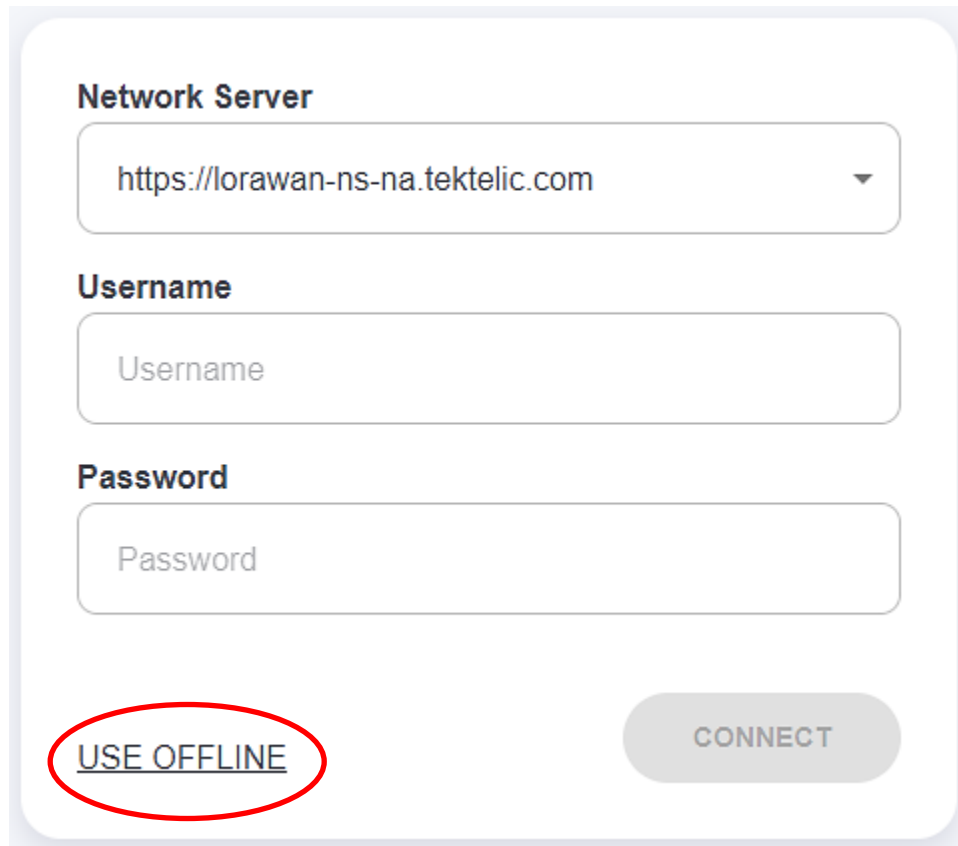

The screenshot shows a login form with the following fields and buttons:

- Network Server:** A dropdown menu with the value "https://lorawan-ns-na.tektelic.com".
- Username:** A text input field with the placeholder "Username".
- Password:** A text input field with the placeholder "Password".
- USE OFFLINE:** A button with the text "USE OFFLINE" circled in red.
- CONNECT:** A button with the text "CONNECT".

Figure 5-1 Login as offline mode

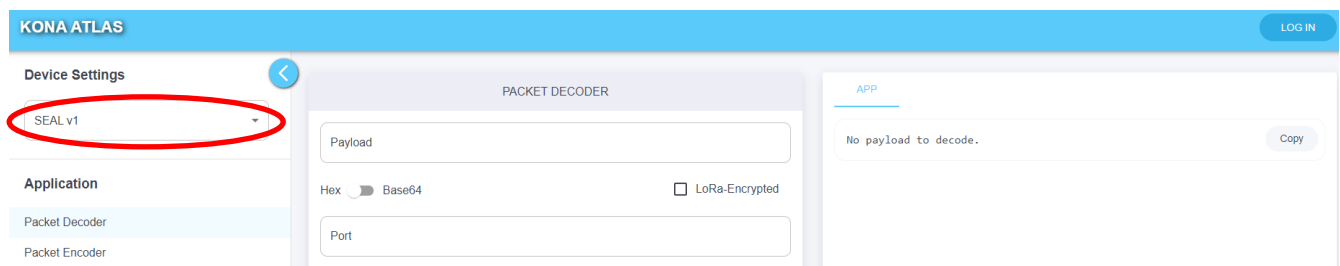

The screenshot shows the KONA ATLAS interface with the following elements:

- Header:** "KONA ATLAS" on the left and "LOGIN" on the right.
- Device Settings:** A sidebar with a dropdown menu showing "SEAL v1" circled in red.
- Application:** A list of applications including "Packet Decoder" and "Packet Encoder".
- PACKET DECODER:** A main section with a "Payload" input field, a "Hex" toggle (set to "Base64"), and a "LoRa-Encrypted" checkbox.
- APP:** A section with a "No payload to decode." message and a "Copy" button.

Figure 5-2 Select SEAL decoder

2) with your TEKTELIC Network Server Credentials

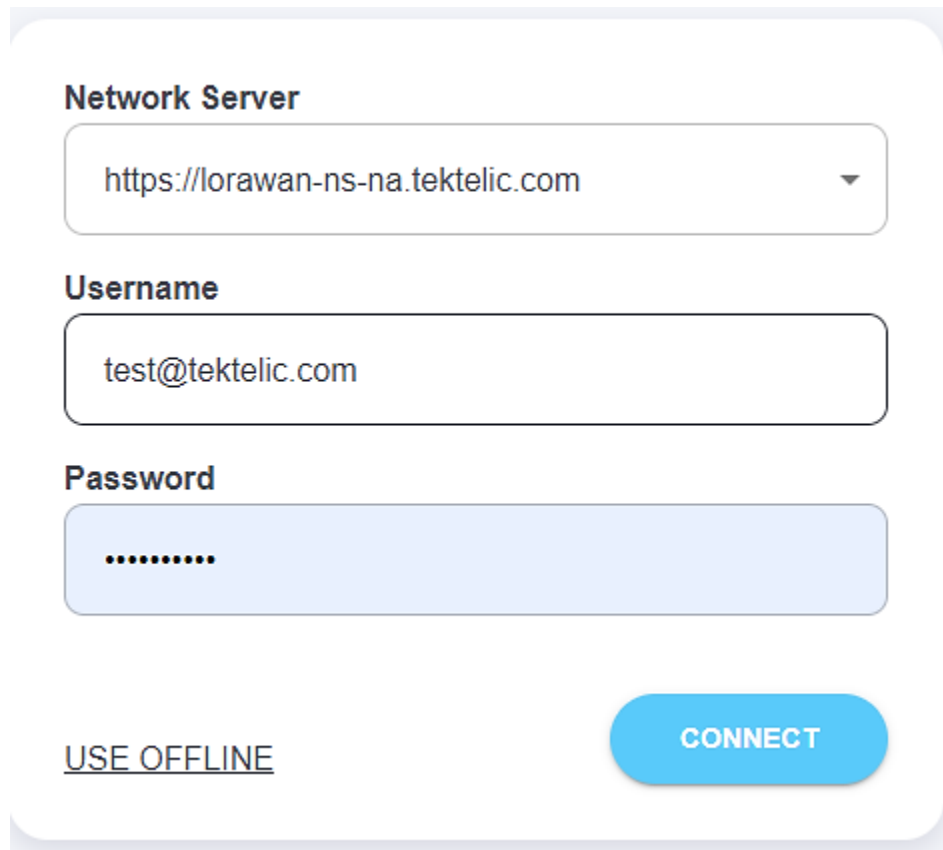

The image shows a login form titled "Network Server". It contains three input fields: "Network Server" with the URL "https://lorawan-ns-na.tektelic.com", "Username" with "test@tektelic.com", and "Password" with a masked field of ten dots. Below the fields are two buttons: "USE OFFLINE" and "CONNECT".

Figure 5-3 Login with Network server credentials

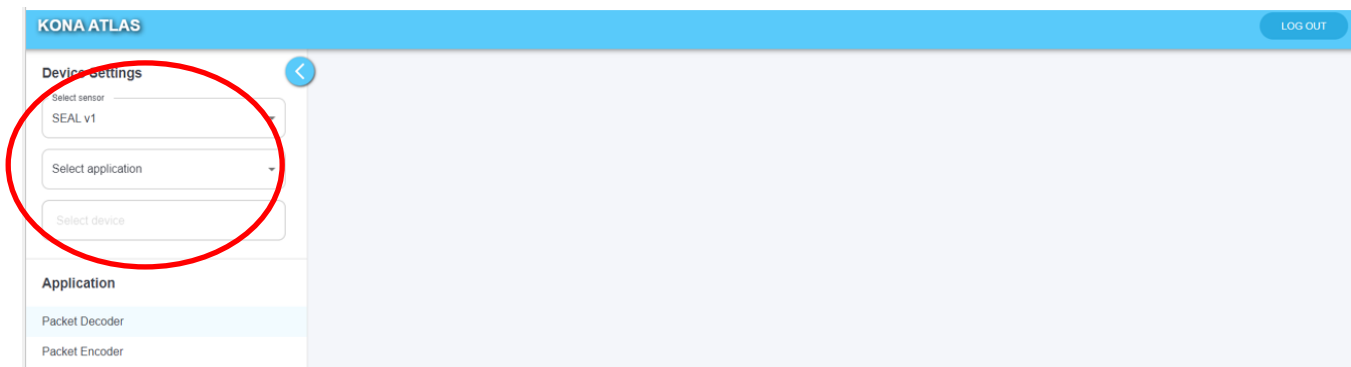

The image is a screenshot of the "KONA ATLAS" web interface. The "Device settings" section is highlighted with a red circle. It contains three dropdown menus: "Select sensor" (SEAL v1), "Select application" (Packet Decoder), and "Select device". Below this, the "Application" section is visible, showing "Packet Decoder" and "Packet Encoder". A "LOG OUT" button is in the top right corner.

Figure 5-4 Select SEAL Decoder, application and the device

For more information follow this link <https://support.tektelic.com/portal/en/kb/articles/kona-atlas>

6 Data converters

Please follow this link: <https://github.com/TektelicCommunications/data-converters/tree/master> for the data converters that are to be used on TEKTELIC & other Network Server for TEKTELIC Sensors. These data converters can be used as a reference for other platforms.

TEKTELIC's data converters conform to the LoRa Alliance Payload Codec Specification and can be used with any 3rd party Network Server / Application Server that supports this specification.

<https://resources.lora-alliance.org/technical-specifications/ts013-1-0-0-payload-codec-api>

7 Compliance Statements

Federal Communications Commission:

This device complies with Part 15 of the FCC Rules. Operation is subject to the following two conditions:

1. This device may not cause harmful interference, and
2. This device must accept any interference received, including interference that may cause undesired operation.

To comply with FCC exposure limits for general population / uncontrolled exposure, this device should be installed at a distance of 20 cm from all persons and must not be co-located or operating in conjunction with any other transmitter.

Changes or modifications not expressly approved by the party responsible for compliance could void the user's authority to operate the equipment. This equipment has been tested and found to comply with the limits for a Class B digital device, pursuant to Part 15 of the FCC Rules. These limits are designed to provide reasonable protection against harmful interference in a residential installation. This equipment generates uses and can radiate radio frequency energy and, if not installed and used in accordance with the instructions, may cause harmful interference to radio communications. However, there is no guarantee that interference will not occur in a particular installation. If this equipment does cause harmful interference to radio or television reception, which can be determined by turning the equipment off and on, the user is encouraged to try to correct the interference by one of the following measures:

- Reorient or relocate the receiving antenna.
- Increase the separation between the equipment and receiver.
- Connect the equipment into an outlet on a circuit different from that to which the receiver is connected.
- Consult the dealer or an experienced radio/TV technician for help.

Innovation, Science and Economic Development Canada (Industry Canada):

This device contains licence-exempt transmitter(s)/receiver(s) that comply with Innovation, Science and Economic Development Canada's licence-exempt RSS(s). Operation is subject to the following two conditions:

- (1) This device may not cause interference, and
- (2) This device must accept any interference, including interference that may cause undesired operation of the device.

This device should be installed and operated with minimum distance 0.2 m from human body.

L'émetteur/récepteur exempt de licence contenu dans le présent appareil est conforme aux CNR d'Innovation, Sciences et Développement économique Canada applicables aux appareils radio exempts de licence. L'exploitation est autorisée aux deux conditions suivantes:

- (1) L'appareil ne doit pas produire de brouillage.
- (2) L'appareil doit accepter tout brouillage radioélectrique subi, même si le brouillage est susceptible d'en compromettre le fonctionnement.

Cet appareil doit être installé et utilisé à une distance minimale de 0.2 m du corps humain.

California Proposition 65:

 **WARNING:** This product can expose you to chemicals including lead, nickel, and carbon black, which are known to the State of California to cause cancer, birth defects or other reproductive harm. For more information, go to www.P65Warnings.ca.gov.

Acronyms and Glossary

BeiDou	BeiDou Navigation Satellite System (BDS), a Chinese satellite navigation system
BER	bit error rate
BLE	Bluetooth Low Energy
bps	bits per second
DL	downlink
EIRP ...	equivalent isotropically radiated power
FCC	Federal Communications Commission
GLONASS	GLObal NAVigation Satellite System
GNSS ...	Global Navigation Satellite System
GPS	Global Positioning System
IoT	Internet of Things
IP	Ingress Protection
LED	light emitting diode
LID	lithium-iron disulfide
LoRa ..	a patented “long-range” IoT technology acquired by Semtech
LoRaWAN	LoRa wide area network (a network protocol based on LoRa)
MCU ..	microcontroller unit
NS	network server
OTA	over the air
PCBA ..	printed circuit board assembly
QZSS ..	Quasi-Zenith Satellite System
RF	radio frequency
RSS	Radio Standards Specifications
RSSI	received signal strength indicator
Rx	receiver, receive
SBAS ..	Satellite-Based Augmentation System
Tracker	any variant of the SEAL Wearable GPS Tracker
TTF ...	time to first fix
TRM ...	technical reference manual
Tx	transmitter, transmit
UG	user guide (this document)
UTC	Coordinated Universal Time
UV	ultraviolet
ver.	version